

# Звёздный АНГЛИЙСКИЙ



# АНГЛИЙСКИЙ ЯЗЫК

## Методические рекомендации к учебнику для начинающих

Пособие для  
общеобразовательных  
учреждений и школ  
с углублённым изучением  
английского языка



Москва  
Express Publishing  
«Просвещение»  
2013

УДК 373.167.1:811.111  
ББК 81.2Англ-922  
А64

Серия «Звёздный английский» основана в 2009 году.

**Авторы:** К. М. Баранова, Д. Дули, В. В. Копылова, Р. П. Мильруд, В. Эванс

**Authors:** Virginia Evans, Jenny Dooley, Ksenia Baranova, Victoria Kopylova, Radislav Millrood

## Acknowledgements

### Authors' Acknowledgements

We would like to thank all the staff at Express Publishing who have contributed their skills to producing this book. Thanks for their support and patience are due in particular to: Megan Lawton (Editor-in-Chief); Mary Swan and Sean Todd (senior editors); Michael Sadler and Steve Miller (editorial assistants); Richard White (senior production controller); the Express design team; Sweetspot (recording producers); and Kevin Harris, Kimberly Baker, Steven Gibbs and Christine Little. We would also like to thank those institutions and teachers who piloted the manuscript, and whose comments and feedback were invaluable in the production of the book.

**Every effort has been made to trace all the copyright holders. If any have been inadvertently overlooked, the publishers will be pleased to make the necessary arrangements at the first opportunity.**

**Английский язык.** Методические рекомендации к учебнику для начинающих / [К. М. Баранова, А64 Д. Дули, В. В. Копылова и др.]. – М. : Express Publishing : Просвещение, 2013. – 160 с.: ил. – (Звёздный английский). – ISBN 978-5-09-027646-7.

*Поурочные методические рекомендации являются обязательным компонентом УМК серии «Звёздный английский» для начинающих. Пособие включает методические советы по работе с учебником, описание целей, задач и содержания уроков, подробное поурочное планирование, аудиоскрипты, ключи к упражнениям учебника и рабочей тетради, карточки и шаблоны для изготовления поделок, таблицы оценивания работы учащихся.*

УДК 373.167.1:811.111  
ББК 81.2Англ-922

## Учебное издание

### Серия «Звёздный английский»

**Баранова** Ксения Михайловна

**Дули** Дженни

**Копылова** Виктория Викторовна

**Мильруд** Радислав Петрович

**Эванс** Вирджиния

## Английский язык

### Методические рекомендации к учебнику для начинающих

Центр группы германских языков

Руководитель Центра *В. В. Копылова*

Зам. руководителя Центра по проектам *И. Н. Темнова*

Руководитель проекта *Ю. А. Смирнов*

Выпускающий редактор *М. А. Семичев*

Редактор *Е. В. Щербакова*

Корректоры *И.Б. Окунева, Н.Д. Цухай*

Налоговая льгота – Общероссийский классификатор продукции ОК 005-93 - 953000. Изд.лиц. Серия ИД № 05824 от 12.09.01. Подписано в печать . Формат 60х90/8. Бумага мелованная. Гарнитура Прагматика. Печать офсетная. Уч.-изд. л. . Тираж экз. Заказ № .

Открытое акционерное общество «Издательство «Просвещение». 127521, Москва, 3-й проезд Марьиной рощи, 41.

Express Publishing. Liberty House, New Greenham Park, Newbury, Berkshire RG19 6HW Tel.: (0044) 1635 817 363 Fax: (0044) 1635 817 463 e-mail: [inquiries@expresspublishing.co.uk](mailto:inquiries@expresspublishing.co.uk) <http://www.expresspublishing.co.uk>

Отпечатано в полном соответствии с качеством предоставленных издательством материалов в ОАО «Тверской ордена Трудового Красного Знамени полиграфкомбинат детской литературы им. 50-летия СССР». 170040, г. Тверь, проспект 50 лет Октября, 46. 

ISBN 978-5-09-027646-7

© Express Publishing, 2013  
© Издательство «Просвещение», 2013  
Все права защищены

# Starlight

## Starter

### Teacher's Book

<b>Introduction</b> .....	p.	4
<b>Programme (Contents &amp; Syllabus)</b> .....	p.	14
<b>Module 1</b> Hello! .....	p.	19
<b>Module 2</b> My Schoolbag .....	p.	27
<b>Module 3</b> My Home .....	p.	35
<b>Module 4</b> My Toys .....	p.	43
<b>Module 5</b> My Face .....	p.	51
<b>Module 6</b> My Food .....	p.	59
<b>Module 7</b> My Animals .....	p.	67
<b>Module 8</b> My Senses .....	p.	75
<b>Fun Time!</b> .....	p.	83
<b>Season's Greetings!</b> .....	p.	85
<b>Mother's Day!</b> .....	p.	87
<b>My Alphabet</b> .....	p.	89
<b>Instruments for Evaluation</b> .....	p.	101
<b>Templates</b> .....	p.	104
<b>Alphabet Picture-Word Cards</b> .....	p.	120
<b>Alphabet Worksheets</b> .....	p.	126
<b>Workbook (Key &amp; Instructions)</b> .....	p.	152

Virginia Evans - Jenny Dooley  
Ksenia Baranova - Victoria Kopylova - Radislav Millrood

# Introduction

**Starlight** is a course designed for Russian specialised language schools. It follows the Russian Standard of Education and aims to introduce young students to the English language. The course has been designed to be covered in approximately 100-110 hours. Young learners will be captivated by the adventures of *Woody* and *Frosty* as they enter the Magic Forest and meet *Erlina*, *Willow* and *Alvin*. Through an array of activities such as stories, songs, games, sticker activities and craftwork, the students will be introduced to theme-oriented vocabulary and some simple structures. In this way, the students will find the learning process enjoyable as they embark on their journey to discover the English language.

**Starlight Starter** contains eight modules.

## Components

### ★ Student's Book

The *Student's Book* has been designed to appeal to, as well as involve, the students in language learning. New language is presented in a clear and effective way by means of lively dialogues, songs, games and listening activities. Each module, comprised of eight lessons including a consolidation section, contains interesting and captivating topics for young learners, reinforced by meaningful activities, which encourage children to think and speak in English. Each page promotes active participation and interaction on their part, as well as the development of their receptive and productive skills.

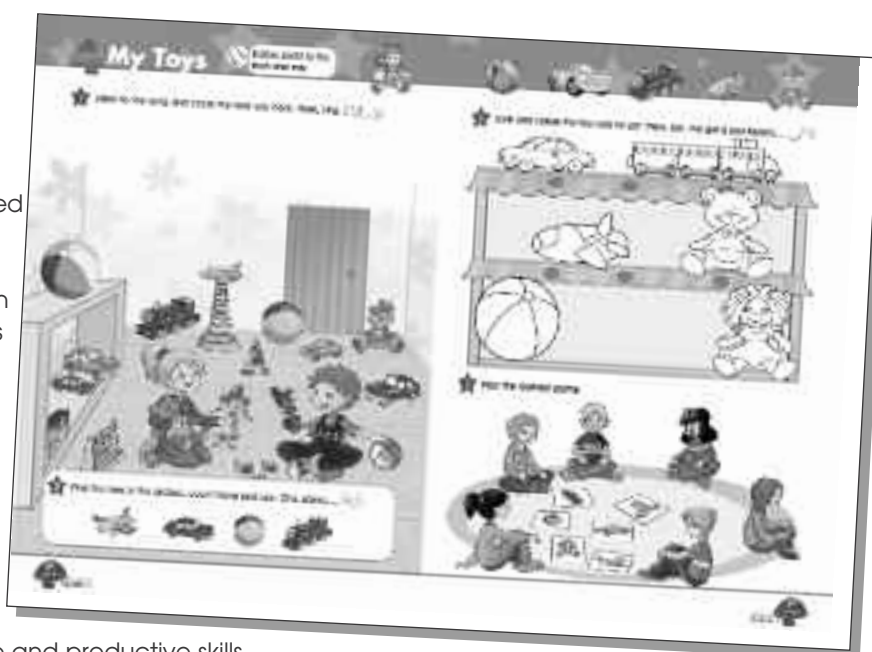

### • Our School

The *OUR SCHOOL* section in the *Student's Book* presents the new language with *cross-curricular* material. The students use English to complete the tasks related to other subject areas, such as *Art*, *Maths*, *Health* and *Safety*, etc. This reinforces their language learning and promotes learner independence and peer cooperation.



- **Dialogues**

Students consolidate the language learnt in simple, yet meaningful and appealing dialogues.



- **Go Green!**

The *GO GREEN!* section gives students the opportunity to learn about the environment in a fun and creative way.

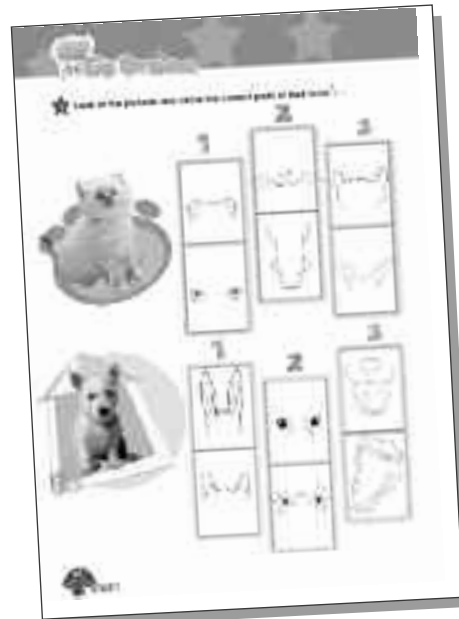

- **Our World/My World**

The students are familiarised with culture and ways of life in other countries, as well as explore their own, through the *OUR WORLD/ MY WORLD* section.



# Introduction

- **Storyland**

*The Giant Turnip* is a story presented in narrative form with lively songs to provide maximum enjoyment and it aims to get the young learners acquainted with Russian folklore. The story recycles key language while introducing new language items to develop the students' comprehension skills.



- **Checkpoint**

The students have the opportunity to recycle and consolidate the language of each module through the *CHECKPOINT* section.

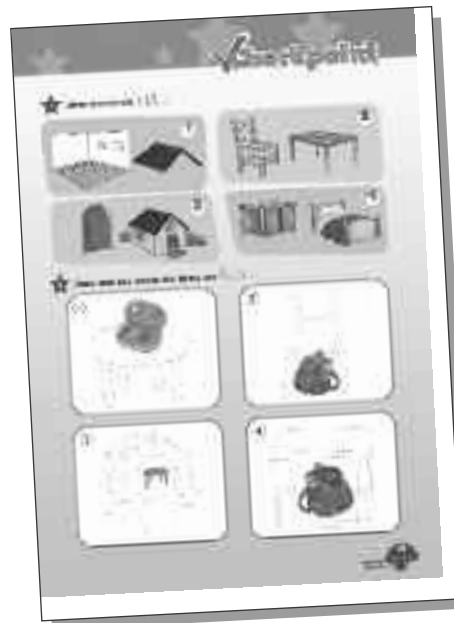

- **My Alphabet**

There is a section at the end of the book that introduces the alphabet to the students. It incorporates listening and writing activities aimed at introducing learners to the sounds of all the letters of the alphabet as well as practicing handwriting skills. It is at the teacher's discretion as to when to cover it, depending on the needs of his/her class.

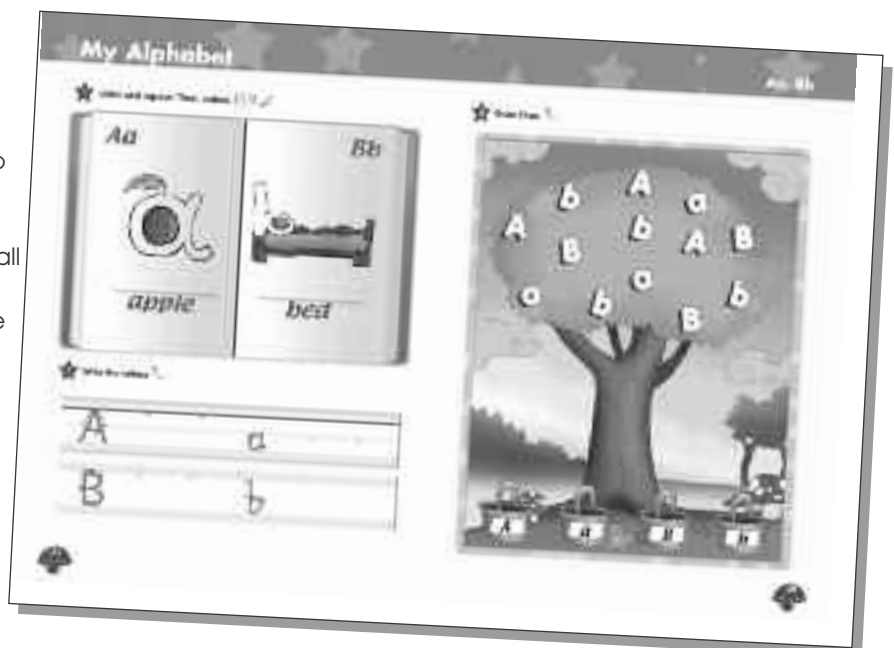



The **Student's Book** also includes:

## I Fun Time!

Students consolidate the language learnt in the course. The teacher can cover this section upon completion of the course or upon completion of a module.

## II Special Days (Season's Greetings!, Mother's Day!)

There are two optional units at the back of the book, containing activities for Christmas and Mother's Day, which should be covered as a lead-up to the respective celebrations.

## ★ Workbook

The *Workbook* is in full colour and contains fun activities, which consolidate the language taught in each module. The *Workbook* can be used either in class or for homework.

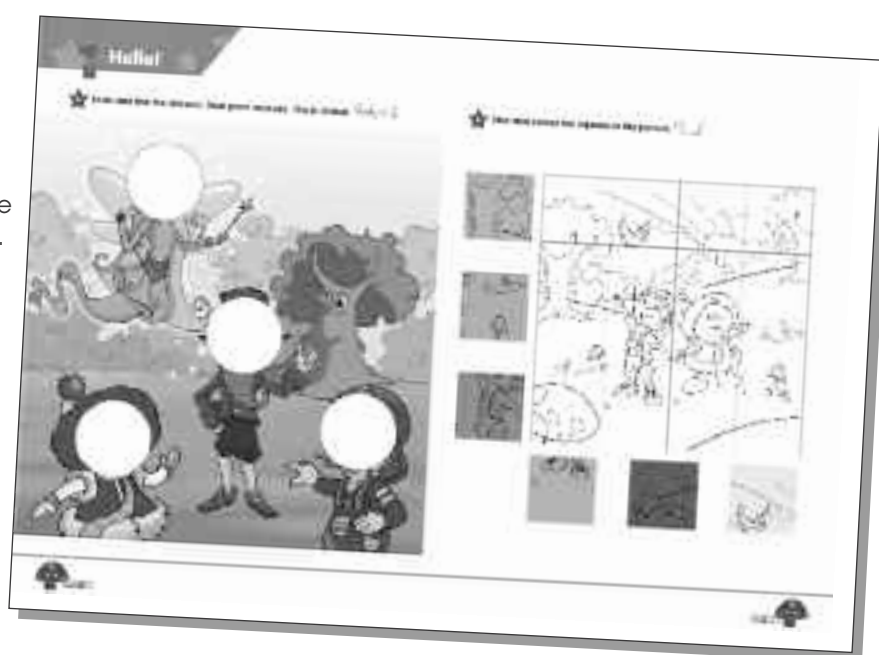

The **Workbook** also includes:

## I Stickers

There are some exercises with **stickers** in the *Workbook*. The type and aim of these exercises vary to give students the chance to practise the new language in a motivating and appealing way. There are also some reward stickers to give a sense of achievement and satisfaction which can be used whenever the teacher feels that the students should be praised, which should be all the time!

## II Board Games

There are four **board games**, one per two modules. The aim of the board games is to provide an atmosphere of relaxation while consolidating the language learnt.

*How to play the board games*

Divide the class into two teams, A and B, or into pairs. Ask the students to use a coin, a pencil sharpener, a rubber, etc., as a marker and place it on the **Start** sign. Teams or pairs take it in turns to select a number by throwing a dice, spinning a spinner, etc., and then move along the board according to the number. The students must name the item in the square they land on. A correct answer allows the students to stay where they are, whereas an incorrect one means that they must move one square backwards. If they land on an *Oh no!* square, they must go back to the beginning. If they land on a *Great!* square, they play again.

### III Character Cutouts

There are five full-body cutouts of the characters in the book, for students to use while acting out the dialogues, playing games or in any other communicative activity the teacher wishes to include in the lesson.

## ★ My Junior Language Portfolio

**My Junior Language Portfolio** is used to keep material that the students collect and use, along with any extra material given by the teacher throughout the course. *My Junior Language Portfolio* has been designed to stimulate and support the learning of the English language. Its purpose is to help the students reflect on, realise their progress in and improve their language learning.

*My Junior Language Portfolio* is the students' property. It is a tool to accompany the students' language learning throughout their school life and is suitable for documenting their learning both inside and outside the classroom.

In practice, *Language Portfolios* may include project work, computer diskettes (with work or drawings completed inside or outside the class), DVDs (with the students' favourite story or with performances of songs, school plays, etc.), certificates, reports from teachers, or even a collection of objects or pictures. It is a collection of material that the learners want to keep as evidence of their learning. The main emphasis is on the process of learning. As a result, while compiling their *Junior Language Portfolios*, students learn how to work independently.

*How to make a Junior Language Portfolio*

During the first lesson, explain to the students that they should bring in a dossier, which they will have with them at all times and in which they will keep their *Junior Language Portfolio*. For the next lesson, bring in self-adhesive labels, write *My Junior Language Portfolio* on them and help your learners stick them onto their dossiers. Demonstrate how to store their material in their *Junior Language Portfolios* and make sure they update it regularly.

### • Certificate of Achievement

This is filled in upon completion of the course. The aim of this certificate is to reward the students, as well as give them a sense of achievement.

## ★ Test Booklet

The **Test Booklet** contains eight photocopiable tests which are to be done upon completion of each corresponding module.

## ★ Teacher's Book

The *Teacher's Book* provides step-by-step lesson plans, as well as the answers to the exercises in both the *Student's Book* and the *Workbook*. It also contains extra ideas on how to present new words and language patterns, additional activities and games, as well as tapescripts for the listening activities.

The **Teacher's Book** also includes:

### I Instruments for Evaluation

Evaluation is an essential part of the learning process. It helps the learners become aware of their progress in the target language, how much they have achieved and what areas need further practice. Evaluation also allows teachers to reflect on the validity of their teaching practices and the types of material being used.



In the **Instruments for Evaluation**, the teacher can find:

- *Formative Evaluation Chart*: The teacher uses the chart to evaluate the students on an activity at any time during the course and writes the marks obtained with the help of a code. (See p. 102 for further information.)
- *Cumulative Evaluation Chart*: The teacher uses the chart to evaluate the students at the end of each module and writes the marks obtained with the help of a code. (See p. 103 for further information.)

## II Templates

The *Templates* are for the craftwork activities in the *Student's Book*.

## III Alphabet Picture-Word Cards

Alphabet Picture-Word Cards are used for activities in the Alphabet section.

## IV Alphabet Worksheets

The teacher can use these extra worksheets for further practice on the Alphabet.

## V Key & Instructions to the Workbook

The teacher can use the key and instructions to the *Workbook* upon completion of each module.

## ★ Picture Flashcards

The **picture flashcards** illustrate the new vocabulary items and enable the teacher to use them for the presentation of key words, revision, additional practice and memory games. Flashcards enable students to make the connection between the visual prompts and the spoken words and help teachers avoid the use of translation or lengthy explanations.

## ★ Posters

There are eight double-sided posters accompanying *Starlight Starter*. On the front side, there is the vocabulary of the first spread as well as the picture accompanying the song. On the back side there is the dialogue for those teachers who wish to present or practise the dialogue with books closed. The book is also accompanied by an *Alphabet Poster* for those teachers who wish to teach/consolidate the English alphabet. In the *Teacher's Book* there are helpful guidelines as to when and how the posters can be used to present and/or consolidate the new language.



## ★ Class CDs

The **Class CDs** include all the recordings for the listening activities in the *Student's Book*.

## ★ Student's CD

The **Student's CD** includes all the vocabulary, chants, songs, dialogues and story so that the students can listen to them at home, thus improving their pronunciation and intonation.

## ★ DVD

The **DVD** brings the characters to life, ensuring that the students have fun while learning. It is suggested that you view each module on the DVD upon completion of the corresponding module in the *Student's Book*.

## ★ Interactive Whiteboard Software

An **Interactive Whiteboard** is a type of touch-sensitive board, connected to a computer. It has the power to transform **any** classroom into a truly stimulating learning environment. The coursebook activities are projected onto the board and every activity is digitally enhanced by additional features such as:

- the audio of the activity,
- videos,
- songs,
- suggested answers and models.

## ★ Typical layout of a module

Each module consists of 8 lessons including a consolidation section. It's up to the discretion of the teacher as to how to teach the lessons depending on the needs of his/her students.

### • Key features of a module

#### I Presentation of the new language

The new language is presented by first listening to the new vocabulary. In each lesson plan the teacher will find detailed guidance on how to vary the presentation of new vocabulary, as well as further reinforcement and extension activities.

#### II Dialogues

The students are introduced to short dialogues, aimed at gradually improving their reading and listening skills. In this way, the students gain an appreciation for reading and are not intimidated by the written word. The dialogues feature the new language which can be used for classroom acting out.

#### III Activities

There is a great variety of activities catering for all types of learners and learning styles: colouring, pair and group work, matching, games, craftwork, etc. In this way, the students use the new language in a meaningful context.

## IV Games, Chants & Songs

Students at this level need a lot of opportunities to play and explore their surroundings. Playing games and singing songs/chants provides a necessary outlet and ensures that the students are learning while having fun. It is also a way of ensuring that the lesson always ends on a high note. In every module, there are songs, chants and games that add a creative and enjoyable element to the language classroom.

## V Our School

In the *OUR SCHOOL* section, the students explore other fields of study (e.g. *Art, Maths, Health and Safety*, etc.) through English. In this way, the students learn how to use English as a vehicle to approach other subject matter.

## VI Go Green!

The *GO GREEN!* section promotes an affinity with nature and makes the students more aware of the environment they live in.

## VII Our World/My World

Through the *OUR WORLD/MY WORLD* section, the students have the opportunity to explore aspects of life in other countries as well as their own.

## VIII STORYLAND

In this section the students are introduced to the story of *The Giant Turnip*, a series of episodes aimed at providing real language input, reading for pleasure, as well as getting the students acquainted with Russian folklore.

## IX CHECKPOINT

This section includes exercises consolidating the module as well as preparing the students for the tests, which can be found in the *Test Booklet*.

## ★ Teaching Young Learners

Teaching young learners is an enjoyable experience. The teacher can take his/her time and repeat an activity as many times as he/she feels is necessary for the students to understand and have fun with it! Moreover, students at this level do not have many inhibitions and can be very imaginative. They are naturally inquisitive, enthusiastic and receptive to new input.

A teacher at this level should always have the following in mind:

- I **Encouragement:** Students need to be reassured all the time. Go around the classroom as they carry out the various activities and praise them. Do not over-emphasise their mistakes. Just repeat the correct word or phrase. Criticism can be discouraging and produce poor results.
- II **Activities:** At this level, the activities should be simple, as students are still developing their hand-eye coordination. On the other hand, students should acquire some basic language structures. Therefore, in the early stages, our objective should be to provide an environment of fun and enjoyment for the young learners. This is best achieved by a thematic approach to language teaching.
- III **The fantasy element:** Young students' imaginations are very vivid and they have the ability to immerse themselves in a fantasy world, often creating imaginary friends and sometimes pretending to be fictional characters (e.g. Superman, Xena, etc.). This rich imagination can be captured and encouraged by the teacher in order to act out the dialogues from the lessons in **Starlight Starter**. Students are very quick to repeat dialogues that they have heard and this ability should be utilised to its full capacity.
- IV **Social Skills:** Young students prefer to play on their own. The sense of being in a social group and obeying rules is not yet fully developed. Thus, the games promote the development of social skills.

- V Students' need for attention:** Young learners will constantly demand your attention. In order to meet their needs, the teacher should go around and talk to them about what they are doing and, at the same time, elicit some vocabulary and language patterns. This is also a good time to see if they have understood everything they have been told or whether there are things which need further explanation.
- VI Attention span:** A student's attention span is very short, so there is a need for a variety of activities. The best way to hold their attention is by changing activities every five to ten minutes. At the same time, they tend to love what is familiar. Thus, you should let a favourite activity go on for as long as they are actively engaged.
- VII The 'silent' period:** It is possible that young students will not produce anything in the target language during the initial stages. This is a period of adjustment and should not alarm teachers. What we should bear in mind is that students are absorbing the new language and will reproduce it naturally in their own time.
- VIII Pronunciation:** Young students are better at pronunciation than older students. That is because they are keener listeners and they are not afraid to make mistakes. Thus, it is vital that teachers speak clearly, but at a **normal** pace. The class should be drilled as a group before moving on to individual practice. In this way, teachers can correct any pronunciation errors without embarrassing individual students, while at the same time giving them time to get used to the new sound(s).

## ★ Classroom Management

Creating a pleasant environment in the classroom should be one of the teacher's very first goals. It is a good idea for the teacher to arrive a few minutes early to welcome the students and have something interesting for the early comers to do. They can listen to the song from the previous lesson, watch the DVD again or play with the picture flashcards, identifying the book's characters, as well as the vocabulary items already presented.

The teacher should establish his/her policies from the start. Remind students to:

- come to class on time,
- bring their *Student's Book*, etc.,
- raise their hands when they want to ask a question,
- wait for their classmates to answer the teacher's questions before they raise their hand to give their answer.

The teacher should empower his/her learners by:

- teaching **classroom language**, i.e. the teacher's instructions, such as *open your books*, *close your books*, etc. Classroom language is the language of communication between teacher and students in the classroom and needs to be taught from day one.
- giving brief and clear oral instructions. The teacher should give or read the instructions. He/She reads them at a slower pace, providing examples and eliciting examples from the students so he/she can be sure that they know what to do.

## ★ Songs in the Language Classroom

Songs are of great value in language learning. They are vivid examples of how the language taught is used in a real context and highlight both pronunciation and intonation. Furthermore, their rhythm enables the students to remember the newly acquired language and stimulates learning.

There are numerous ways to use songs in the language classroom. You can play the CD and invite the students to move and clap to the rhythm or hum to the melody. If there are lyrics frequently repeated, students will soon start joining in.

Here are some ways to animate the songs:

- a Total Physical Response (TPR) Activities:** Have the students stand in a circle and play the song once. Sing and demonstrate the actions, encouraging the students to imitate you. Play the song again, this time asking the students to listen to the song and repeat after you while doing the actions. Play the song a third time and lead the singing while the students join in.
- b Using props:** Bring visuals or realia to class. Hand out these props to your students and ask them to hold up the prop as soon as they hear the equivalent word in the song.

- c **Song dramatisations:** Having interesting plots and characters, songs frequently offer themselves for further exploitation through drama. The teacher can dramatisise the songs into short sketches, thus motivating his/her students. Assign roles and have the students sing their lines. Simple costumes and props can be prepared and used to make the performance more realistic.

These are just a few suggestions on how to use the songs in the language classroom. Be as inventive as you can, since students love performing.

## **Types of learning styles**

Over the years, teachers have noticed that some of their students learn by listening to new information, some students prefer to read about it, while others need to do something with the new information. There are many different learning styles. Consequently, a coursebook should offer a variety of exercises and material to stimulate all learning styles and help students learn in the way that suits them best.

- **What are the types of learning styles?**

- **Visual Learners**

These learners need to see the teacher's body language and facial expressions to fully understand the content of the lesson. They think in pictures and learn best from visual displays including: diagrams, illustrations, transparencies, videos, flashcards and handouts.

- **Auditory Learners**

These learners learn best through verbal lectures, discussions, talking things through and listening to what others have to say. Written information may have little meaning until it is heard. They often benefit from using a tape recorder.

- **Tactile/Kinaesthetic Learners**

Tactile/Kinaesthetic people learn best through a hands-on approach, actively exploring the physical world around them. They find it hard to sit still for long periods and may become distracted by their need for activity and exploration. These learners express themselves through movement. They have a good sense of balance and hand-eye coordination. By interacting with the space around them, they are able to remember and process information. They have to do things on their own to be able to learn the new language.

# Programme (Contents & Syllabus)

## » Module 1

**In this module students will ...**

**talk about ...**

- greetings
- colours

**listen to ...**

- the characters introducing themselves
- a song welcoming students to the Magic Forest
- a song consolidating colours
- a dialogue with the characters meeting for the first time

**learn how to ...**

- introduce themselves and greet others
- identify colours
- say what their favourite colour is

### **CRAFTWORK**

**Students will ...**

- cut out the character's stick puppets and use them for role-play

### **OUR SCHOOL**

**Students will ...**

- colour a picture of Frosty (Art)

### **GO GREEN**

**Students will ...**

- talk about colour in nature
- make frog craft

### **PORTFOLIO**

**Students will ...**

- draw a picture of themselves and their favourite colour

### **OUR WORLD/MY WORLD**

**Students will talk about ...**

- colours used for public amenities in the UK and Germany
- colours used for public amenities in Russia

### **LANGUAGE FOCUS**

**Structures**

- Hello, I'm ...
- Who's this?
- My favourite colour is ...

### **Vocabulary**

- names of the characters
- colours: red, blue, green, yellow, pink, orange

## » Module 2

**In this module students will ...**

**talk about ...**

- school objects
- numbers 1-5

**listen to ...**

- a song practicing school objects
- a dialogue about Woody and Frosty's first day at school

**learn how to ...**

- identify school objects
- count from 1-5

### **OUR SCHOOL**

**Students will ...**

- count school objects and trace the correct number (Maths)

### **GO GREEN**

**Students will ...**

- talk about living and non-living things

### **PORTFOLIO**

**Students will ...**

- draw a picture of their school objects

### **OUR WORLD/MY WORLD**

**Students will talk about ...**

- popular playground games in the UK and Cuba
- popular playground games in Russia

### **LANGUAGE FOCUS**

**Structures**

- What's this? It's a ...
- Let's count!
- How many ...?

### **Vocabulary**

- school objects; schoolbag, pencil, book, pen, rubber, pencil case
- numbers 1-5



## » Module 3

**In this module students will ...**

**talk about ...**

- parts of a house
- furniture

**listen to ...**

- a song practising parts of a house
- a song presenting and practising prepositions of place and furniture
- a dialogue about Woody and Frosty's tree house

**learn how to ...**

- identify parts of a house
- talk about location

### **CRAFTWORK**

**Students will ...**

- make a house

### **OUR SCHOOL**

**Students will ...**

- make furniture items out of clay or plasticine (Art)

### **GO GREEN**

**Students will ...**

- talk about animals and their homes

### **PORTFOLIO**

**Students will ...**

- draw a picture of their room

### **OUR WORLD/MY WORLD**

**Students will talk about ...**

- fairytale characters and their houses
- a Russian fairytale

### **LANGUAGE FOCUS**

**Structures**

- This is the roof. It's red.
- Little Woody's on the chair.
- Where's the blue book? On the table.

**Vocabulary**

- parts of a house: roof, window, floor, wall, door
- furniture: table, chair, bed, cupboard

## » Module 4

**In this module students will ...**

**talk about ...**

- toys
- numbers 6-10
- size (*big - small*)

**listen to ...**

- a song practising toys
- a song practising numbers 1-10
- a dialogue about the characters playing with their toys

**learn how to ...**

- identify toys
- talk about their toys
- count from 1 to 10
- talk about size

### **CRAFTWORK**

**Students will ...**

- make number finger puppets

### **OUR SCHOOL**

**Students will ...**

- do sums and find the toys (Maths)

### **GO GREEN**

**Students will ...**

- talk about reusing coffee cans

### **PORTFOLIO**

**Students will ...**

- draw a picture of their favourite toy

### **OUR WORLD/MY WORLD**

**Students will talk about ...**

- toys from the UK and Russia
- Storyland

### **LANGUAGE FOCUS**

**Structures**

- Here's a doll.
- One train, four cars.
- I've got a brown teddy bear.
- A big ball, a small ball.

# Programme (Contents & Syllabus)

## Vocabulary

- toys: doll, ball, car, train, plane, teddy
- numbers 6-10
- size: big, small

## ►► Module 5

**In this module students will ...**

**talk about ...**

- parts of the face
- how to keep clean

**listen to ...**

- a song practising parts of the face
- a description of four monsters
- a song practising ways to keep clean and healthy

**learn how to ...**

- identify parts of the face
- talk about keeping clean and healthy

## CRAFTWORK

**Students will ...**

- make a monster mask

## OUR SCHOOL

**Students will ...**

- talk about ways to keep clean (Health & Safety)

## GO GREEN

**Students will ...**

- identify animals according to their facial characteristics

## PORTFOLIO

**Students will ...**

- draw a picture of Mr/Miss Potato

## OUR WORLD/MY WORLD

**Students will talk about ...**

- cartoon characters from the UK and Russia

## LANGUAGE FOCUS

**Structures**

- Touch your eyes.
- I've got blue hair.
- Brush your hair.

## Vocabulary

- parts of the face: nose, hair, ears, eyes, mouth, tongue
- commands: wash your hands, wash your face, brush your teeth, brush your hair

## ►► Module 6

**In this module students will ...**

**talk about ...**

- food
- food preferences

**listen to ...**

- a song practising food preferences
- a song practising food items
- a dialogue about the characters having a picnic

**learn how to ...**

- talk about food preferences

## CRAFTWORK

**Students will ...**

- make a lunchbox

## OUR SCHOOL

**Students will ...**

- talk about food that is bad for our teeth (Health & Safety)

## GO GREEN

**Students will ...**

- talk about food we get from cows, hens and trees

## PORTFOLIO

**Students will ...**

- draw a picture of their favourite food

## OUR WORLD/MY WORLD

**Students will talk about ...**

- tea in the UK, China and Turkey

## LANGUAGE FOCUS

**Structures**

- I like bananas. Give me some, please.

# Programme (Contents & Syllabus)

- I don't like apples. Yuk!
- Do you like ice cream? Yes. Yummy!

## Vocabulary

- food/drink items: bananas, eggs, milk, sandwiches, biscuits, cheese, tea, pizza, apples, popcorn, ice cream, cola

## » Module 7

**In this module students will ...**

**talk about ...**

- animals
- abilities

**listen to ...**

- a song practising farm animals
- a song practising abilities
- a dialogue about some forest animals helping Woody and Frosty

**learn how to ...**

- identify animals and the noises they make

## CRAFTWORK

**Students will ...**

- make animal puppets

## OUR SCHOOL

**Students will ...**

- play a drama game (PE & Drama)

## GO GREEN

**Students will ...**

- talk about what some animals can do

## PORTFOLIO

**Students will ...**

- draw a picture of a farm

## OUR WORLD/MY WORLD

**Students will talk about ...**

- animals from Australia, Peru, China and Russia

## LANGUAGE FOCUS

**Structures**

- The sheep goes baa!
- Look! Two yellow cows!

- It's a horse. It can jump.
- Can you jump? Yes.
- I can swim.

## Vocabulary

- animals: cat, cow, hen, dog, sheep, horse
- actions: jump, climb, swim, fly, run

## » Module 8

**In this module students will ...**

**talk about ...**

- the five senses

**listen to ...**

- a song practising the five senses
- a song consolidating the concept of day and night
- a dialogue about the characters having a fairy party

**learn how to ...**

- talk about the senses

## CRAFTWORK

**Students will ...**

- make a bat
- make a senses book

## OUR SCHOOL

**Students will ...**

- identify actions connected with day and night (Science)

## GO GREEN

**Students will ...**

- talk about nocturnal animals

## PORTFOLIO

**Students will ...**

- draw a picture connected with day or night

## OUR WORLD/MY WORLD

**Students will talk about ...**

- things you can see, hear and taste in the UK, Italy and Russia

# Programme (Contents & Syllabus)

## LANGUAGE FOCUS

### Structures

- It's night! I can see the moon.
- I can smell a flower.

### Vocabulary

- the five senses: see, hear, smell, touch, taste
- sun, moon, day, night, stars

## ▶▶ Fun Time!

### In this section students will ...

- consolidate the key vocabulary of the course

## ▶▶ Season's Greetings!

### In this unit students will ...

- sing a Christmas song
- offer gifts to the characters
- make a card for the holidays

## ▶▶ Mother's Day!

### In this unit students will ...

- sing a Mother's day song
- make a bunch of flowers for their mums

## ▶▶ My Alphabet

### In this section students will ...

- be introduced to the English Alphabet

## Lesson 1

### Objectives

To introduce the characters. To practise greetings and introductions.

### Language

In this lesson the students will learn to **understand**:

- *Who's this?*
- *This is (Willow).*
- *Open/Close your books.*
- *Who is it?*
- *What's your name?*

In this lesson the students will learn to **use**:

- *Yes/No.*
- *Hello, I'm (Kelly).*
- *Goodbye, (Sue).*

### Extra Materials

- The *Hello!* poster for *Presentation & Practice*;
- character cut-outs for Ex. 3.

## BEGINNING THE LESSON

Welcome your class by saying *Hello!* several times. Point to yourself and say: *I'm (Mrs Smith).*

Ask the students to look at the cover of their books and invite them to comment on it, in L1. What can they see? Read the title and explain what it means. Tell the students that they are going to learn about a magic forest with special creatures.

**Note:** Use this opportunity to trigger the students' interest in their books, and the English they are going to learn.

## PRESENTATION & PRACTICE

(Activities to familiarise the students with the characters.)



### POSTER

**Students' books closed.** Put up the *Hello!* poster on the board. Point to the characters (*Willow, Erlina, Alvin, Woody, Frosty*), one at a time, and present them. The students repeat after you. Point to the characters in random order. The students listen and say *yes* or *no*. Demonstrate this yourself first.

e.g. *Teacher: (pointing to Willow) This is Erlina.*  
*Class: No!*  
*Teacher: (pointing to Frosty) This is Frosty.*  
*Class: Yes! etc*

**Students' books open.** Say: *Open your books at page four.* Write the number 4 on the board and hold up

your book. Ask the students to look at the picture and tell you what they can see in L1. Point to Willow and ask: *Who's this?* Elicit the answer. Repeat with the rest of the characters.

**1 Listen and point to the characters. Then, say: Hello, I'm (Erlina). (TRACK 02)**

Play the recording. The students listen and point to the characters. Then students point to the characters and say, e.g. *Hello, I'm (Erlina).*

### TAPESCRIPT

*Hello, I'm Erlina.*  
*Hello, I'm Willow.*  
*Hello, I'm Alvin.*  
*Hello, I'm Woody.*  
*Hello, I'm Frosty.*

**2 Who are they? Find them in the picture and say: This is (Erlina).**

(An activity to develop the students' pre-reading skills.)

Do the first one with the students as an example. Point to Erlina's mouth and say: *Who is it? Let's see. Is it Alvin?* Elicit the response: *No. Is it Erlina? Who is it?* Ask a student to give the answer. Ask them to circle Erlina's mouth in the picture. Help them by holding up your book and drawing an imaginary circle over Erlina's mouth. Allow the students some time to look at the picture and complete the activity. Check the students' answers.

(Activities to practise greetings.)

**3 Cut out the stick puppets. Use them to talk with your friend. Say: Hello, I'm (Willow). Hello, I'm (Frosty).**

Refer the students to the picture and explain the activity. Ask the students to go to their Workbooks (Cutout section p. 74) and cut out the stick puppets. Provide any necessary help. With the help of a student demonstrate the following short dialogue:

e.g. *Teacher: (in the role of Erlina) Hello, I'm Erlina.*  
*Student 1: (in the role of Alvin) Hello, I'm Alvin.*

The students choose a character and go around the classroom meeting and greeting the rest of the characters.

### Extension

The students sit in a circle. Explain the activity. One of the students sits in the centre and covers his/her eyes. Choose a student from the circle to say: *Hello, (Tina).* The student in the centre has to guess who it is and

# Module 1 – Hello!

respond by saying: *Hello, (Kelly)*. If (Tina) guesses correctly, (Kelly) goes in the centre. If not, they must try with another person from the circle.

e.g. *Kelly: Hello, Tina!*  
*Tina: Hello, Kelly! etc*

## ★ 4 Listen and sing. (TRACK 03)

Point to the characters, one at a time, and say: *Hello, Magic Forest! Hello, Magic Friends! Hello, (Willow)! The students repeat after you. Explain what *magic forest* and *magic friends* mean.*

Point to and say: *HELLO*. Play the recording. The students listen and point to the characters as their names are mentioned.

Play the recording again. The students listen and sing along.

### TAPESCRIPT

*Hello, Magic Forest,  
Hello, Magic Friends!  
Hello, Frosty! Hello, Woody!  
Hello, hello again!  
Hello, Magic Forest,  
Hello, Willow, too!  
Hello, Erlina! Hello, Alvin!  
Hello, hello to you!*

### Extension

Assign the roles of *Frosty, Woody, Willow, Erlina* and *Alvin* to various students. They can hold the corresponding cut-outs. The rest of the class are in the Magic Forest and are meeting them. Play the song. The students move around the classroom singing and waving hello to the characters. The students who play the characters wave back.

## ENDING THE LESSON

*(An activity to consolidate the language of the lesson.)*

Point to the characters on the *Hello!* poster, one by one. Say and wave: *Goodbye, (Willow)*. The students repeat after you.

Address a student and ask: *What's your name?* The student responds. Then the rest of the class says goodbye to him/her. Repeat the procedure with the rest of the class. Demonstrate this yourself first.

e.g. *Teacher: What's your name?*  
*Student 1: Sue.*  
*Class: Goodbye, Sue!*

## WORKBOOK (Optional)

If you wish, you can do Exs 1 and 2 from the *Workbook* during this lesson or the next one.

### Lesson 2

#### Objectives

To present and practise colours. To explore other subject areas: Art.

#### Language

In this lesson the students will learn to **understand**:

- *What's your favourite colour?*
- *Who's this?*
- *What colour is this?*

In this lesson the students will learn to **use**:

- *Colours: red, blue, green, yellow, pink, orange.*
- *(It's) orange.*

#### Extra Materials

- Coloured crayons for *Presentation & Practice*;
- coloured ribbons, one per five students for Ex. 2 (*Extension*).

## BEGINNING THE LESSON

*(An activity to review the language from the previous lesson.)*

Play the recording for Ex. 1 from the previous lesson (Track 02) and pause before the name of each character. Ask the students to say who it is and greet them.

e.g. *Teacher: (plays the recording with Erlina talking)*  
*Hello, I'm ...*  
*Class: Erlina! Hello, Erlina! etc*

## PRESENTATION & PRACTICE

*(Activities to present and practise colours.)*

### ★ Listen, point to the colours and say. (TRACK 04)

**Students' books closed.** Show the red crayon and say: *red*. The students repeat after you. Repeat with the rest of the colours (*blue, green, yellow, pink, orange*). Put the crayons on your desk in random order. Ask a student to come to the front of the class. Say: *yellow*. The student picks up the corresponding crayon, shows it to the classroom and says: *yellow*. Ask the rest of the class for verification. Repeat with as many students as you think is necessary.



**Students' books open.** Say: *Open your books at page six.* Write the number 6 on the board and hold up your book. Play the recording. The students listen, point to the colours and repeat.

Address a student and ask as you point to the colours: *What's your favourite colour?* Elicit a response: *(Blue).* Ask other students to point to and say their favourite colours.

## TAPESCRIPT

*Red, blue, green, yellow, pink, orange.*

### 1 Look and colour the picture.

Elicit the name of the character and the colours. Say: *Who's this? What colour is this?* Explain the activity. The students look at the coloured picture and colour the big picture accordingly. Check the students' answers by asking them to point to and say the colour, e.g. *(It's) orange.*

### 2 Listen and sing. (TRACK 05)

Point to the globe and say: *world.* The students repeat after you. Say as you point to the red ribbon: *Colour my world red.* The students repeat after you. Say as you point to the blue ribbon: *Colour my world blue.* The students repeat after you. Repeat with the rest of the colours *(pink, yellow, green).*

Play the recording. The students listen and point to the coloured ribbons. Play the recording again. The students listen and sing along.

## TAPESCRIPT

*Colour my world,  
Colour my world,  
Colour it red and blue!*

*Colour my world,  
Colour my world,  
Colour it yellow, too!*

*Colour my world,  
Colour my world,  
Colour it pink and green!*

*Colour my world,  
Colour my world,  
Colour my world for me!*

## Extension

### Before going into class

Bring sets of coloured ribbons, one per 5 students.

Divide the class into groups of five. Hand a set of coloured ribbons to each group. Help them tie the ribbons together. Play the recording. The students, in groups, walk in a circle as they sing along.

### 3 Play the Colour Bingo game.

Invite the students to colour in any five squares on their Bingo card in any combination of colours. Then call out the colours *(red, blue, yellow, green, orange, pink)* in random order. As you do so, the students cross out the corresponding colour on their card (only one square each time). The first student to cross out his/her squares calls out *BINGO* and is the winner.

## ENDING THE LESSON

*(An activity to consolidate the language of the lesson.)*

Say a colour, e.g. *blue.* The students whose favourite colour is blue stand up and leave the classroom. Encourage them to say *Goodbye!* as they leave. Repeat with the rest of the colours and until all the students have left the classroom.

## WORKBOOK (Optional)

If you wish, you can do Exs 3, 4, 5 and 6 from the *Workbook* during this lesson or the next one.

### Lesson 3

#### Objectives

To listen to a story about how Frosty and Woody met Willow, Alvin and Erlina. To develop listening comprehension skills through a dialogue.

#### Language

In this lesson the students will learn to **understand**:

- *Who's this?*

In this lesson the students will learn to **use**:

- *Hello, (Frosty).*
- *Goodnight.*
- *Hello, I'm (Frosty).*
- *Come with me!*
- *Welcome (to the Magic Forest)!*

#### Extra Materials

- The *Hello!* poster for *Presentation & Practice*;
- A4 sheets of paper for each student for the *Ending the Lesson* activity.

# Module 1 – Hello!

## BEGINNING THE LESSON

(An activity to revise colours.)

Show students a coloured pencil, e.g. red. Ask a student to say the colour. Ask the rest of the class for verification. Repeat with as many students as you think is necessary.

## PRESENTATION & PRACTICE

(Activities to present the story and develop students' listening skills.)

**1** Listen to the story and point to the pictures.  
(TRACK 06)



POSTER

**Students' books closed.** Use the *Hello!* poster to present the story. Point to Frosty in the first picture and ask: *Who's this?* Elicit: *Frosty*. Say as you wave: *Hello, Frosty*. The students repeat after you. Repeat with the rest of the pictures.

Explain to the students, in L1 if necessary, that Frosty is a snowman and Woody is a puppet. They both came to life magically and set out on a magical journey!

**Students' books open.** Say: *Open your books at page eight.* Write the number 8 on the board and hold up your book. Ask students to identify the characters they know.

e.g. Student 1: (pointing to Frosty in Frame 1) (This is) Frosty! etc

Play the recording and ask the students to point to each picture in their book in turn. Show them what to do by holding up your book and pointing. Play the recording again with pauses for the students to listen and repeat chorally.

Point to the first picture on the poster. Ask the students to complete your sentences.

e.g. Teacher: Hello, ...  
Class: Frosty, etc

### Extension

Ask for a volunteer to come and point to the first picture on the poster. Encourage him/her to say the dialogue. Ask the rest of the class for verification. Repeat with the rest of the pictures.

### TAPESCRIPT

#### Frame 1

Girl: Hello, Frosty.

#### Frame 2

Man: Hello, Woody.

#### Frame 3

Man: Goodnight.

#### Frame 4

Woody: Hurray!

#### Frame 5

Frosty: Hello, I'm Frosty.

Woody: Hello. I'm Woody.

#### Frame 6

Woody: Come with me!

#### Frame 7

Willow: Hello, I'm Willow.

#### Frame 8

Erlina: Welcome!

Read the question at the bottom of page 9. Ask the students to draw a happy face or a sad face, depending on whether they like the story or not. Ask them to tell you, in L1 if necessary, what they like most.

## ENDING THE LESSON

(An activity to consolidate the language of the lesson.)

Provide the students with a piece of paper. Ask the students to draw their own Magic Forest. They can draw trees of different colours. Encourage them to present their Magic Forest to the class by saying: *Welcome to the Magic Forest!*

### Lesson 4

#### Objectives

To talk about colours in nature.

#### Language

In this lesson the students will learn to **understand**:

- What colour is the (sun)?
- sun, tree, apples, oranges, frog, flower

In this lesson the students will learn to **use**:

- (It's) green.
- Hello, I'm (Max the frog).

#### Extra Materials

- Green & red construction paper, glue, scissors, markers for each student for Ex. 3.

## BEGINNING THE LESSON

(An activity to review the language from the previous lesson.)

Play the dialogue from the previous lesson (Track 06). The students listen and follow in their books.

## PRESENTATION & PRACTICE

(Activities to talk about colours in nature.)

### 1 Nature is full of colours! Colour the picture. Then, point and say: (Green).

**Students' books closed.** Draw a simple sketch of the sun on the board. Point to it and ask: *What colour is the sun? Red? Blue? What colour is it?* Elicit: *Yellow*. Follow the same procedure with *tree, apple, orange, frog* and *flower*.

**Students' books open.** Say: *Open your books at page ten*. Write the number 10 on the board and hold up your book. Tell students, in L1 if necessary, that nature is full of colours. Ask them to colour in the items. Then students point to and say the colours.

e.g. Student 1: (pointing to the sun) *It's yellow. etc*

### 2 Complete the pictures. Then, colour them.

Explain the activity. Allow the students some time to complete and colour in the drawings. Go around the classroom as the students complete the activity. Provide any necessary help.

### 3 Make your own frog!

#### Before going into class

Bring green and red construction paper for each student.

Hand out the green construction paper to the students. Show your model and help the students make their own frog.

- 1  Ask them to fold the paper in thirds.
- 2 Then, they fold it in fourths to make a 'w' shape.
- 3 This is their frog. Ask them to draw a pair of eyes on it.

- 4 Hand out the red paper to the students. Ask them to cut out a long tongue from the red paper and glue it into the frog's mouth. Their frog is ready!

## ENDING THE LESSON

(An activity to consolidate the language of the lesson.)

The students name their frogs and present them to the class.

e.g. Student: *Hello, I'm Max the frog.*

### Lesson 5

#### Objectives

- To consolidate the language learnt in the module.
- To draw a picture of oneself.

#### Language

In this lesson the students will learn to **understand**:

- *What colour is the (sun)?*

In this lesson the students will learn to **use**:

- *red, blue, green, yellow, pink, orange*
- *Hello, I'm (Alvin).*
- *My favourite colour is ...*

#### Extra Materials

- A4 sheets of paper for each student for the *Ending the Lesson* activity.

(Activities to consolidate colours.)

## BEGINNING THE LESSON

Draw a circle on the board. Ask the students to do the same in their notebooks. Say: *It's yellow*. The students colour the circle yellow. Repeat with the rest of the colours.

## PRACTICE

### 1 Find four mistakes in the picture.

Draw a picture of a sun on the board. Point to it and ask: *What colour is the sun?* Elicit responses (*yellow*). Follow the same procedure with the *frog, bananas* and *water*. Then, ask the students to go to the picture in their books and look at the sun there. Ask: *Is the sun yellow?* Elicit a response (*no*). Allow the students some time to find and circle the mistakes. Check their answers.

**Items to be circled:** water, frog, sun, bananas

# Module 1 – Hello!

## ★ 2 What colour is next? Colour, then say.

Explain the activity. Allow the students some time to complete the activity. Then, students point to and name the colours. Ask the rest of the class for verification.

- 1 Students colour the circle red.
- 2 Students colour the circle yellow.
- 3 Students colour the circle green.

## ★ 3 What is their favourite colour? Listen and circle. Then, say: *Hello, I'm (Alvin). My favourite colour is ...* . (TRACK 07)

Point to the buckets and elicit the colours. Play the recording, twice if necessary. The students listen and circle the correct colour.

### Items to be circled:

Alvin – green  
Erlina – pink  
Frosty – orange  
Woody – blue

### TAPESCRIPT

*Hello, I'm Alvin. My favourite colour is green.*

*Hello, I'm Erlina. My favourite colour is pink.*

*Hello, I'm Frosty. My favourite colour is orange.*

*Hello, I'm Woody. My favourite colour is blue.*

### Extension

Invite students to take the parts of Alvin, Erlina, Woody and Frosty. If you wish, they can use the character stick puppets. The students, in role, say what their favourite colour is.

*e.g. Student 1: (in the role of Alvin) Hello, I'm Alvin. My favourite colour is green. etc*

## ★ 4 Portfolio: Draw a picture of yourself. Present it to the class: *Hello, I'm ... . My favourite colour is ...* .

*(An activity to develop fine motor skills and consolidate the language of the module.)*

Point to the picture and elicit the colour. Then say: *Hello, I'm (John). My favourite colour is red.* Ask the students to draw a similar picture about themselves and their favourite colour and present it to the class. Make sure you display their work somewhere in the classroom. Then help them file their drawings in their *Junior Language Portfolios*.

## ENDING THE LESSON

*(An activity to consolidate the language of the lesson.)*

Provide the students with a sheet of paper. Ask the students in groups to choose a colour and make a collage of pictures/drawings with this colour. Make sure you display their work somewhere in the classroom.

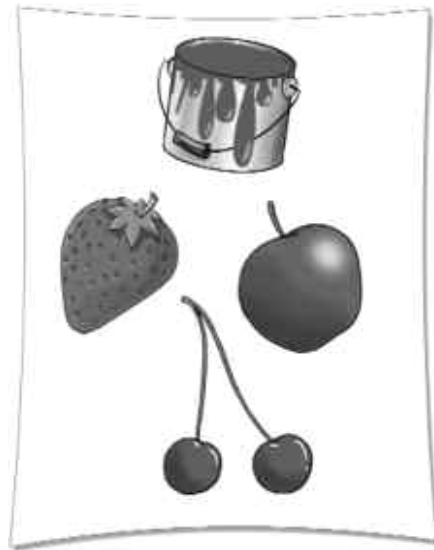

### Lesson 6 – Our World/My World

#### Objectives

To familiarise students with British and German culture and compare it with their own. To talk about things that are red/yellow in the UK/Germany/Russia.

#### Language

In this lesson the students will learn to **understand**:

- *UK, Germany, Russia.*
- *What colour is this?*
- *bus, mail box, tram*

In this lesson the students will learn to **use**:

- *(It's) red.*
- *My favourite colour is (red).*

#### Extra Materials

- A map of the world for Ex. 1 (Optional).

## BEGINNING THE LESSON

*(An activity to revise colours.)*

Ask the students to present the drawing they made in the previous lesson.

## OUR WORLD

(Activities to familiarise students with aspects of British and German culture.)

### 1 Look at the pictures. Point and say the colours.

**Students' books open.** Say: *Open your books at page fourteen.* Write the number 14 on the board and hold up your book. Point to the British flag and say: *UK.* If you have a map of the world, put it up on the board and show where the UK is. Ask the students if they know anything about the UK and have a class discussion in L1 (e.g. *famous people, cities, etc.*). Explain to the students that in this section they will be learning a lot of interesting things about this country. Point to the items and elicit the colour (*red*). Explain that the mail boxes and the buses in London are red.

Point to the German flag and say: *Germany.* If you have a map of the world, put it up on the board and show where Germany is. Elicit the colour of the items (*yellow*).

## MY WORLD

(Activities for the students to explore and talk about their own culture in English.)

### 2 What colour are they? Colour, point and say.

Point to the title and the flag and explain in L1 that in this section they will be talking about their own country, city, lifestyle, etc. Explain the activity. Point to the tram and ask: *What colour is it in (Moscow)?* Elicit the right response. Repeat with the mail box. Allow the students some time to colour in the pictures. Then students present their complete pictures. Alternatively, the students draw and colour similar pictures in their notebooks.

#### Optional Activity

Ask the students to find pictures of things in public places that are the same colour and bring them to class. Have a class discussion.

### 3 Play the Musical Colours game.

Ask the students to make six strips of paper and colour them (*red, blue, green, yellow, pink, orange*). Ask them to place the strips of paper in front of them. Explain the game. Play a song from the module. Pause the song and say a colour, e.g. *blue*. The students have to raise the corresponding strip of paper.

## ENDING THE LESSON

(An activity to consolidate the language of the lesson.)  
Do a survey. Put up coloured pieces of paper (*red, blue, green, yellow, orange, pink*) on the board. Ask the students, one at a time, to come and tick (✓) their favourite colour and say: *My favourite colour is (red).* Then, count the ticks and see which colour is the most popular one. Say: *(Red) is our favourite colour.*

### Lesson 7 – Storyland

#### Objectives

To listen to a Russian story in English. To develop listening and speaking skills.

#### Language

In this lesson the students will learn to **understand**:

- *What's this?*
- *Yes, it's a little seed.*

In this lesson the students will learn to **use**:

- *seed, big, small, eat, grow, garden, plant, like*
- *Please grow very big. I like turnips!*

#### Extra Materials

- Flashcards (1-7) for *Presentation & Practice*,
- A4 sheets of paper for each student for the *Ending the Lesson* activity.

## BEGINNING THE LESSON

(An activity to present fairy tales as a concept.)

Write the words *fairy tale* on the board and explain the meaning. Ask the students to name some of their favourite fairy tales in L1. Then tell them they are going to listen to the story of *The Giant Turnip*. Initiate a class discussion by asking the students to say what they know about the tale.

## PRESENTATION & PRACTICE

(Activities to present the tale of 'The Giant Turnip'.)

### ★ Listen, point to the pictures and repeat. (TRACK 08)



#### FLASHCARDS (1-7)

**Students' books closed.** Put up the flashcards on the board, one at a time. Point to the items on the flashcards (*seed, big/small, eat, grow, garden, plant*) and present them. The students repeat after you. Point to the flashcards in random order and ask questions. Elicit responses from different students. Demonstrate this yourself first.

# Module 1 – Hello!

e.g. Teacher: (pointing to the seed flashcard)  
What's this?  
Class: Seed. etc

**Students' books open.** Say: *Open your books at page sixteen.* Write the number 16 on the board and hold up your book. Play the recording. The students listen, point and repeat.

## TAPESCRIPT

*Seed, big, small, eat, grow, garden, plant.*

## ★ Listen to the story. (TRACK 09)

Direct the students' attention to the picture. Point to the characters and present them. Explain/Elicit the English words for *dog, cat* and *mouse*.

Play the recording for the students to listen to the story. Play the recording again. The students listen and point to the characters as they are mentioned. Play the CD a third time with pauses. The students listen and repeat, chorally and/or individually.

## TAPESCRIPT

*One day, an old man goes to his garden. He plants a turnip seed. "Please grow very big!" the old man says. "My wife likes turnips. Little Anna likes turnips. The dog and the cat like turnips! The mouse likes turnips, too!"*

## 1 Listen and sing. (TRACK 10)

Ask the students to look at the pictures. Point to the little seed and ask: *What's this?* Elicit responses (*seed*). Say: *Yes, it's a little seed. Little seed, you look so sweet!* The students repeat after you. Follow the same procedure to present the rest of the song.

Play the recording. The students listen. Play the recording again. The students listen and sing along.

## TAPESCRIPT

*Little seed,  
You look so sweet!  
Little seed  
Little seed!  
Turnip seed, very small  
Grow, turnip, grow  
Turnip seed, very small  
We love turnips so!*

*Little turnip,  
Nice and round!  
Little turnip,  
Little turnip,*

*Turnip seed, very small*

*Grow, turnip, grow  
Turnip seed, very small  
We love turnips so!*

*Giant turnip,  
Look at you!  
Giant turnip,  
Giant turnip!*

*Turnip seed, very small  
Grow, turnip, grow  
Turnip seed, very small  
We love turnips so!*

## ENDING THE LESSON

(An activity to consolidate the language of the lesson.)

Provide the students with a sheet of paper. Ask the students to draw a picture of a turnip. Tell them to draw a picture of themselves as well. Help them present their drawing and say: *Please grow very big! I like turnips!*

## Lesson 8 – Checkpoint

### Objectives

To consolidate the language of the module.

## 1 Listen and circle. (TRACK 11)

Explain the activity. The students listen and circle the characters mentioned. Check the students' answers.

**The students circle:** Willow, Woody, Alvin.

## TAPESCRIPT

- 1 This is Willow. Hello, Willow!
- 2 This is Woody. Hello, Woody!
- 3 This is Alvin. Hello, Alvin!

## 2 Listen and colour. (TRACK 12)

Explain the activity. The students listen and colour the pictures. Check the students' answers.

## TAPESCRIPT

- 1 red
- 2 blue
- 3 green
- 4 yellow
- 5 orange
- 6 pink

**Note:** The students are now ready to do Module Test 1.



## Lesson 1

### Objectives

To present and practise the names of school items.

### Language

In this lesson the students will learn to **understand**:

- Show me (red)!
- What's this?
- What colour is it?

In this lesson the students will learn to **use**:

- School objects: schoolbag, pencil, book, pen, rubber, pencil case.
- My (pen) is (blue).
- It's a (book)!

### Extra Materials

- Crayons for the *Beginning the Lesson* activity;
- the *My Schoolbag* poster for *Presentation & Practice*;
- a feely bag for Ex. 4.

## BEGINNING THE LESSON

(An activity to revise colours.)

Welcome your class by saying 'Hello!' to each student and eliciting the same response.

Ask the students to put their crayons (*red, blue, green, yellow, pink and orange*) on their desks. Say a colour at random and ask them to hold up the corresponding crayon. Vary the rhythm and speed of the instructions to make the activity like a game.

e.g. Teacher: Show me (red)!  
Class: (holds up the red crayon) etc

## PRESENTATION & PRACTICE

(Activities to present school objects.)

 **Listen, point to the school objects and say.**  
(TRACK 13)



**Students' books closed.** Put up the *My Schoolbag* poster on the board. Point to the school objects (*schoolbag, pencil, book, pen, rubber, pencil case*), one at a time, and say the word(s). The students repeat after you. Point to the objects in random order. The students repeat after you.

**Students' books open.** Say: *Open your books at page twenty.* Write the number 20 on the board and hold up

your book. Play the recording. The students listen, point to the school objects and repeat.

### TAPESCRIPT

*Schoolbag, pencil, book, pen, rubber, pencil case.*

(Activities to practise school objects.)

 **1 Colour the school objects. Then, talk with your friend: My (pen) is (blue).**

Point to the items, one at a time, and elicit the words. Revise the colours by pointing to different items around the classroom and eliciting the colour. Allow the students time to colour the school items. Then, ask students, in pairs, to talk about their pictures. Demonstrate this yourself with a student first.

e.g. Teacher: My book is red.  
Student 1: My book is yellow. etc

 **2 Listen and point. Then, sing. (TRACK 14)**

Point to the schoolbag and say: *What's in your schoolbag? Let's take a look!* The students repeat after you. Play the recording. The students listen and point to the items as they are mentioned.

Play the recording again. The students listen and sing along.

### TAPESCRIPT

*What's in your schoolbag?  
Let's take a look:  
A pencil, a pen,  
A rubber, a book!*

### Extension

Ask the students to put their schoolbag, a pencil, a pen, a rubber and a book on their desks in random order. Play the recording again. The students point to the items in front of them in the order they hear them.

 **3 Complete the pictures. Then, point and say: It's a (book).**

Refer the students to the pictures and explain the activity. Ask the students to use their pencils to trace the pictures. The students can then colour the objects. Then, point to each object individually and ask students to say what it is.

e.g. Teacher: (pointing to book) *What's this?*  
Student 1: *It's a book.*  
Teacher: *What colour is it?*  
Student 2: *Red.* etc

# Module 2 – My Schoolbag

## Extension

The students close their books. Point to different school objects around the classroom and elicit the words.

### ★ 4 Play the *Feely Bag* game.

#### Before going into class

Bring a feely bag into class and put different items the students know in it (e.g. a pencil, a pencil case, a book, a rubber, etc) without letting the students see what is in the bag.

Refer the students to the picture and explain the game. Ask individual students to put their hand in the feely bag and feel an object. Ask: *What's this?* The student says what the item is and then takes it out of the bag. Elicit the response: *It's a ...*. Ask the rest of the class for verification. Demonstrate this yourself with a student first. As an extension, you can have individual students take your role and the game is repeated.

## ENDING THE LESSON

(An activity to consolidate the language of the lesson.)

Tell the students they are going to play *Bingo*. Ask them to draw simple sketches of a schoolbag, pencil, book, pen, rubber and a pencil case on different slips of paper and place them on their desks. Say the objects at random. The students listen and turn the corresponding slips of paper face down. When they have turned all their slips face down, they raise their hands. The game ends when you have said all the words and all the students have raised their hands.

### WORKBOOK (Optional)

If you wish, you can do Exs 1 and 2 from the *Workbook* during this lesson or the next one.

## Lesson 2

### Objectives

To present and practise numbers 1-5. To explore other subject areas: Maths.

### Language

In this lesson the students will learn to **understand**:

- *Let's count!*
- *How many ...?*
- *Two flowers!*

In this lesson the students will learn to **use**:

- Numbers 1-5 (*one, two, three, four, five*).

### Extra Materials

- A4 sheets of paper for each student for the *Ending the Lesson* activity.

## BEGINNING THE LESSON

(An activity to revise the language from the previous lesson.)

Play the recording for Ex. 2 from the previous lesson (Track 14) and pause before each school item. Ask the students to say the school item.

e.g. Teacher: (plays the recording) *What's in your...*  
Class: *schoolbag? etc*

## PRESENTATION & PRACTICE

(Activities to present and practise numbers 1-5.)

### ★ Listen and say the numbers. (TRACK 15)

**Students' books closed.** Hold up a finger and ask the students to do the same. All together say: *One*. Do the same for all five fingers. Next, invite the students to count aloud from 1 to 5, holding up their hands and counting on their fingers at the same time. Say: *Let's count!*

### Extension

Say a number, e.g. *three*. Ask a student to show the corresponding number of fingers and repeat the number. Ask the rest of the class for verification. Repeat with as many students as you think is necessary.

**Students' books open.** Say: *Open your books at page twenty-two*. Write the number 22 on the board and hold up your book. Play the recording. The students listen, point to the numbers and repeat.

## TAPESCRIPT

One, two, three, four, five.

### Extension

Collect different items and put them in groups (e.g. 1 schoolbag, 2 pencils, 3 pencil cases, 4 pens, 5 pencils). Ask the students: *How many (pencils)?* and elicit responses (e.g. *Three (pencils)!*). Repeat with as many students as necessary.

### 1 Count the items and circle the correct number.

Explain the activity. The students look at the pictures and circle the appropriate number according to each picture. Check the students' answers by asking them to point to and say the number of items, e.g. *One, two, three, four. Four (pens)!*

3 books    2 schoolbags    5 rubbers

### 2 Count and write the numbers. Then, draw the correct number of flowers.

Draw 2 flowers on the board, point to them and say: *two flowers*. The students repeat after you. Write number 2 underneath. Now draw 3 flowers, point to them and say: *three flowers*. The students repeat after you. Write number 3 underneath. Now point to all the flowers and say: *five flowers*. The students repeat after you. Draw 5 flowers and write number 5 underneath. Ask the students to repeat the same procedure and do the exercise. Allow them some time to complete the activity. Check their answers and write them on the board.

$1 + 2 = 3$  (draw three flowers)

$3 + 2 = 5$  (draw five flowers)

### 3 Play the Number game.

Refer the students to the picture. Tell the students they are going to play a game. Have the students stand in a circle, preferably with their chairs behind them. Choose a student to be Number 1 and he/she says the number out loud. The student on his/her left is Number 2, the next student is Number 3, etc. Students take turns and say their numbers out loud. The student who is Number 5 says his/her number out loud, introduces him/herself to the rest of the group (e.g. *5 – Hello, I'm Jack.*) and sits on his/her chair. The student next to him/her starts the game again by saying "One" and the game continues. The student who is already sitting on the chair is out of the counting process. The game continues until all the students sit down.

## ENDING THE LESSON

(An activity to review numbers 1-5.)

Provide the students with a sheet of paper. Ask them to draw as many pencils (up to five) as they wish and write the number below them. They hand in their drawings as they leave the classroom. Make sure you display their drawings in the classroom so that the children can see them during the next lesson and feel proud of their work. While the students are drawing, feel free to play the song from the previous lesson.

### WORKBOOK (Optional)

If you wish, you can do Exs 3, 4 and 5 from the *Workbook* during this lesson or the next one.

### Lesson 3

#### Objectives

To listen to a story about Frosty and Woody's first day at school. To develop listening comprehension skills through a dialogue.

#### Language

In this lesson the students will learn to **understand**:

- *How many ...?*
- *Time for school!*

In this lesson the students will learn to **use**:

- *What's this?*
- *It's a ...!*

#### Extra Materials

- The *My Schoolbag* poster for *Presentation & Practice*;
- A4 sheets of paper for each student for the *Ending the Lesson* activity.

## BEGINNING THE LESSON

(An activity to review numbers 1-5.)

Draw some school items on the board (e.g. 2 pens, 4 rubbers, 1 schoolbag, 3 books, 5 pencils). Ask individual students to tell you how many items of each kind they can see and ask the rest of the class for verification. Repeat with as many students as you think is necessary.

e.g. *Teacher: How many pens?*

*Student 1: Two (pens)! etc*

# Module 2 – My Schoolbag

## PRESENTATION & PRACTICE

(Activities to present the story and develop students' listening skills.)

### 1 Listen to the story and point to the pictures. (TRACK 16)



#### POSTER

**Students' books closed.** Use the *My Schoolbag* poster to present the story. Explain to the students, in L1 if necessary, that it's Frosty and Woody's first day at school. Erlina is their teacher and she uses magic to teach them new and exciting things. Point to Willow in the first picture and ask: *Who's this?* Elicit: *Willow*. Say as you mime ringing the bell: *Time for school!* The students repeat after you. Point to Erlina in the second picture and say: *Hello!* The students repeat after you. Repeat with the rest of the pictures.

**Students' books open.** Say: *Open your books at page twenty-four.* Write the number 24 on the board and hold up your book. Ask students to identify the characters they know.

e.g. Student 1: (pointing to Woody in Frame 1) (This is) Woody! etc

Play the recording and ask the students to point to each picture in their books in turn. Show them what to do by holding up your book and pointing. Play the recording again. The students listen and repeat, chorally and/or individually.

Point to the first picture on the poster. Ask the students to complete your sentences.

e.g. Teacher: *Time for ...*  
Class: *school! etc*

#### Extension

Ask for a volunteer to come and point to the first picture on the poster. Encourage him/her to say the dialogue. Ask the rest of the class for verification. Repeat with different students for the rest of the story.

#### TAPESCRIPT

##### Frame 1

Willow: *Time for school!*

##### Frame 2

Erlina: *Hello!*

##### Frame 3

Erlina: *What's this?*  
Frosty: *It's a pen!*

##### Frame 4

Erlina: *No, it isn't. Look again!*

##### Frame 5

Erlina: *What's this?*  
Woody: *It's a book!*

##### Frame 6

Erlina: *No, it isn't. Look again!*

##### Frame 7

Erlina: *1, 2, 3 ...*

##### Frame 8

Woody: *Magic schoolbags!*

Read the question at the bottom of page 25. Ask the students to draw a happy face or a sad face, depending on whether they like the story or not. Ask them to tell you, in L1 if necessary, what they like most.

## ENDING THE LESSON

(An activity to consolidate the language of the lesson.)

Provide the students with a sheet of paper. Ask the students to draw their own school. They can draw items of different colours. Encourage them to present their school to the class by saying *Time for school!*

### Lesson 4

#### Objectives

To talk about living and non-living things.

#### Language

In this lesson the students will learn to **understand**:

- *living things/non-living things*
- *eat, breathe, have babies, grow*
- *ant, bat, tree*

In this lesson the students will learn to **use**:

- *It's (red).*

#### Extra Materials

- None.

## BEGINNING THE LESSON

(An activity to revise the dialogue.)

Play the dialogue from the previous lesson (Track 16). The students listen and follow in their books.

## PRESENTATION & PRACTICE

(Activities to talk about living and non-living things.)

## ★ 1 Look at the picture. Colour the living things.

**Students' books closed.** Draw a simple sketch of a book and a bat on the board. Point to the book and ask: *What's this?* Elicit: *It's a book.* Follow the same procedure with *bat*. Explain to the students that a book is a non-living thing, whereas a bat is a living thing. Tell students, in L1 if necessary, that living things can eat, breathe, grow and have babies.

**Students' books open.** Say: *Open your books at page twenty-six.* Write the number 26 on the board and hold up your book. Point to the pictures at the bottom of the page and explain the actions shown, which are typical of living things (*have babies, eat, breathe, grow*). Ask the students to look at the picture and colour the living things using the colours they already know. Allow them time to complete the activity and check their answers by having them point to and name the colour they have used.

e.g. Student 1: (pointing to the bat) *It's (red).*

ants    bat    flowers    tree

## ★ 2 Draw in the right box.

Point to the pictures and elicit which are living and which are non-living things. Explain the activity. The students draw the living things in the box where the baby is and the non-living things where the book is. Allow the students some time to complete the activity. Check their answers. Alternatively, you can assign it as homework.

## ENDING THE LESSON

(An activity to consolidate the language of the lesson.)

The students think of one more living and non-living thing and add it to the list.

### (Suggested answers)

Living – flower, bat, ant, etc

Non-living – bus, pencil, school, etc

## Lesson 5

### Objectives

- To consolidate the language learnt in the module.
- To draw a picture of school objects.

### Language

In this lesson the students will learn to **understand**:

- *How many (pencil cases)?*

In this lesson the students will learn to **use**:

- *One, two, three, four five.*
- *This is my (pencil). It's (yellow).*

### Extra Materials

- Flashcards (8-13) for the *Ending the Lesson* activity.

## BEGINNING THE LESSON

(An activity to revise the language from the previous lesson.)

Point to items and people in the classroom. Elicit which are living and which are non-living things.

## PRACTICE

(Activities to consolidate numbers and school items.)

### ★ 1 How many? Count. Write the right number.

Point to the pencil case and ask: *What's this?* Elicit responses (*a pencil case*). Then, ask the students to look at the table as you ask: *How many pencil cases?* Elicit the correct response (*four*). Repeat with the rest of the items. Allow the students some time to write the right number. Check their answers.

sharpener: 2

rubber: 3

schoolbag: 1

pencil: 5

### ★ 2 What's next? Complete and say the number.

Explain the activity. Allow the students some time to complete the activity. Then, students point to and say the right number of stars. Ask the rest of the class for verification.

two green stars, three red stars, five red stars.

# Module 2 – My Schoolbag

## ★ 3 Listen and circle. Then, say: *Five books, ...* . (TRACK 17)

Point to the pictures and elicit the school objects. Play the recording, twice if necessary. The students listen and circle the number of items they hear on the recording. Then point to each group and ask: *How many?* Have individual students respond, e.g. *five (books)*.

**Items to circled:** 5 books, 3 pens, 2 rubbers

### TAPESCRIPT

*Five books.  
Three pens.  
Two rubbers.*

## ★ 4 Portfolio: Draw a picture of your school objects. Present them to the class and say: *This is my (pencil). It's (yellow).*

*(An activity to consolidate the language of the module.)*

Point to the picture and elicit the items. Then say: *This is my pencil. It's yellow.* Ask the students to draw a similar picture of their school objects and present it to the class. Make sure you display their work somewhere in the classroom. Then help them file their drawings in their *Junior Language Portfolios*.

## ENDING THE LESSON

*(An activity to consolidate the language of the lesson.)*



### FLASHCARDS (8-13)

Pick a school item flashcard (e.g. schoolbag) but do not reveal what it is. Show it to the students really quickly. Ask students to name the school item. Do the same with the remaining flashcards.

### WORKBOOK (Optional)

If you wish, you can do Ex. 6 from the *Workbook* during this lesson or the next one.

## Lesson 6 – Our World/My World

### Objectives

To familiarise students with British, Cuban and Russian culture. To talk about playground games in the UK, Cuba and Russia.

### Language

In this lesson the students will learn to **understand**:

- *UK, Cuba, Russia*
- *playground games (tug of war, hopscotch)*
- *Correct! One point for Team A!*

In this lesson the students will learn to **use**:

- *Go to school! School is cool! Say your name and go to school! (Ma-ri-a)!*

### Extra Materials

- Flashcards (8-13) for Ex. 3 (*Game*);
- slips of paper with numbers 1-5 for the *Ending the Lesson* activity.

## BEGINNING THE LESSON

*(An activity to revise the language from the previous lesson.)*

Ask the students to present the drawings they made in the previous lesson.

## OUR WORLD

*(Activities to familiarise students with aspects of British and Cuban culture.)*

## ★ 1 Look at the pictures. Listen to the song. Then, play a playground game popular in the UK. (TRACK 18)

**Students' books closed.** Ask the students, in L1 if necessary, what games they usually play at school during the break. Explain to them that today they are going to learn about popular *playground games* in the UK and Cuba.

**Students' books open.** Say: *Open your books at page thirty.* Write the number 30 on the board and hold up your book. Point to the British flag and say: *UK.* Repeat the same procedure with the flag of Cuba. Point to the pictures and ask the students if they know the games. Point to the first picture and say: *Tug of war.* Explain the game if they do not know it. *(Two parallel lines are drawn or painted on the grass. The rope is laid perpendicular to these lines. A cloth flag is tied to the middle of the rope. The two teams position themselves along the rope on either side of one of the lines. The*



referee makes certain the flag is positioned precisely mid-way between the two lines. On his own command, he releases the flag and shouts, "Go!" Both teams then pull on their end of the rope. The aim is to pull the flag over the team's goal line.)

Repeat the procedure with *hopscotch*. (The game starts with the player throwing the marker to square number 1. The player then hops from square to square in sequence, skipping the square with the marker. The player should hop with only one foot in each square at any one time.)

Play the recording. The students listen to the chant and sing. Explain the game. Two students stand in the middle and clap hands together and then clap their partner's hands forming an archway. The rest of the class passes under the archway as they chant.

## TAPESCRIPT

Go to school!  
School is cool!  
Say your name  
And go to school!  
Ma-ri-a!

Go to school!  
School is cool!  
Say your name  
And go to school!  
John-a-than!

## MY WORLD

(Activities for the students to explore and talk about their own culture in English.)

### ★ 2 Look and say the names of the games.

Explain the activity. Point to the pictures and elicit, in L1, the names of the games: *Dodgeball*, *Sea Rolls*. Ask students, in L1 to tell you the rules of the games:

**Dodgeball:** Children in the middle of the playground try to avoid the ball which is thrown at them by two children standing by two sides of the playground. Those who are touched by the ball, leave the game. The winner is the one who remains after all the players left the game.

**Sea Rolls:** Children in the middle make various movements imitating sea-creatures while the leader counts "The sea rolls once, the sea rolls twice, the sea rolls thrice. The sea-creatures freeze!" After he/she says "freeze", the children in the middle should freeze in the position they were. The leader goes around them for

some time and if he sees that someone moves even a bit, that person leaves the game.

## Optional Activity

Ask the students to find or draw pictures of popular playground games and bring them to class. Have a class discussion.

### ★ 3 Play the Memory game.



#### FLASHCARDS (8-13)

Put up five of the six flashcards on the board. Write a number 1-5 below each one. Allow the students some time to look at the school objects carefully and memorise their place on the board before they close their eyes. Then, flip the flashcards over so they face the board. Divide the class into two teams, A and B. Say a number. Ask a student from Team A to tell you which school object corresponds to that number. Flip the card over and ask the rest of the class for verification. If the student finds the correct item, Team A gets one point. If not, the point goes to Team B. The team with the most correct answers wins the game. Rearrange the school items on the board and repeat the game as many times as you wish.

e.g. Teacher: 2  
Student 1 Team A: A rubber!  
Teacher: Correct! One point for Team A!  
etc

## ENDING THE LESSON

(An activity to consolidate the language of the lesson.)

### Before going into class

Write the numbers 1 to 5 on separate slips of paper.

Hand out the slips to five students at random. Invite the students to come to the front and tell them to arrange themselves in a line from 1 to 5, depending on the number they are holding. Then ask the whole class to count from 1 to 5. The student holding the number is his or her slip when they hear the number.



## Lesson 7 – Storyland

### Objectives

To listen to a Russian story in English. To develop listening and speaking skills.

### Language

In this lesson the students will learn to **understand**:

- *What's this?*
- *Yes, it's a giant turnip.*

In this lesson the students will learn to **use**:

- *pull, call*

### Extra Materials

- Flashcards (14-15) for *Presentation & Practice*.

## BEGINNING THE LESSON

(An activity to revise the story.)

Ask the students if they remember what the previous episode of the story was about. If not, ask them to go to the respective page (16) and look at the picture.

## PRESENTATION & PRACTICE

(Activities to present the tale of 'The Giant Turnip'.)



**Listen, point to the pictures and repeat.**  
(TRACK 19)



**FLASHCARDS (14-15)**

**Students' books closed.** Put up the flashcards on the board, one at a time. Point to the items on the flashcards (*pull, call*) and present them. The students repeat after you. Mime the actions. The students name them.

**Students' books open.** Say: *Open your books at page thirty-two.* Write the number 32 on the board and hold up your book. Play the recording. The students listen, point and repeat.

### TAPESCRIPT

*Pull, call.*



**Listen to the story.** (TRACK 20)

Direct the students' attention to the picture. Point to the characters and present them. Point to the turnip and say: *What's this? Look! It's a giant turnip. Can the old man pull the giant turnip? Let's see!* Play the

recording for the students to listen to the story. Play the recording again. The students listen and point to the characters as they are mentioned. Play the CD a third time with pauses. The students listen and repeat, chorally and/or individually.

### TAPESCRIPT

*The turnip grows and grows and grows. It's a big giant turnip! The old man is very happy. He starts to pull the turnip. He pulls and pulls. But he can't pull the turnip out. "I need help," he says. So he calls his wife.*

## ENDING THE LESSON

(An activity to consolidate the language of the lesson.)

Narrate the story. The students mime it.

## Lesson 8 – Checkpoint

### Objectives

To consolidate the language of the module.



**1 Use the code and colour the picture.**

Explain the activity. The students use the code and colour in the picture. Allow the students some time to complete the activity. Check the students' answers by asking what colour the items are.

e.g. Teacher: (*pointing to the tree*) *What colour is it?*  
Student: *Green.*



**2 Count the school objects. Trace the right number.**

Elicit the names of the school items. Explain the activity. The students count and trace the right number. Check the students' answers.

2 pencils   3 schoolbags   4 rubbers

**Note:** The students are now ready to do Module Test 2.

## Lesson 1

### Objectives

To present parts of a house. To revise colours.

### Language

In this lesson the students will learn to **understand**:

- *What's this?*
- *What colour is the (door)?*

In this lesson the students will learn to **use**:

- *Parts of a house: house, roof, window, floor, wall, door.*
- *(This is the) roof.*
- *This is my house.*
- *The (window) is (green).*

### Extra Materials

- The *My Home* poster for *Presentation & Practice*;
- photocopies of the house template (p. 104) for each student for Ex. 4;
- flashcards (16-21) for the *Ending the Lesson* activity.

## BEGINNING THE LESSON

*(Activities to review the language of the previous lesson.)*

Ask a student to come to the board. Say a school object. The student draws a rough sketch of the object on the board. Ask the rest of the class for verification. Repeat with all school objects.

Review the numbers by saying a number and having a student write it on the board. Ask the rest of the class for verification. Repeat with as many students as necessary.

## PRESENTATION & PRACTICE

*(Activities to present and practise the vocabulary of the lesson.)*



POSTER

### ★ Listen, point to the parts of the house and say. (TRACK 21)

**Students' books closed.** Put up the *My Home* poster on the board. Point to the parts of the house (*house, roof, window, floor, wall, door*), one at a time, and present them. The students repeat after you.

Point to the different parts in random order and ask questions. The students name them. Demonstrate this yourself first.

e.g. Teacher: *(pointing to the roof) What's this?*

Class: *(This is the) roof. etc*

**Students' books open.** Say: *Open your books at page thirty-four.* Write the number 34 on the board and hold up your book. Play the recording. The students listen, point and repeat.

### TAPESCRIPT

*House, roof, window, floor, wall, door.*



### 1 Colour the parts of the house. Then, say: *This is the (roof). It's (red).*

Revise the colours. Elicit the names of the different parts of a house by pointing and asking: *What's this?* Explain the activity. The students look at the picture and colour it in using any combination of colours they like. Once they finish, ask the students to describe their pictures by saying: *This is the (door). It's (brown). etc*



### 2 Listen and point. Then, sing and do. (TRACK 22)

Point to the tree house on the poster and say: *This is my house.* The students repeat after you. Follow the same procedure to present the rest of the song.

Play the recording. The students listen and point to the parts of the house. Play the recording again. The students listen and sing along.

### TAPESCRIPT

*This is my house.*

*This is the roof.*

*This is the window.*

*This is the door.*

*This is my house.*

*This is the roof.*

*This is the wall.*

*This is the floor.*

### Extension

Mime the actions for the song:

***This is my house.*** *(make a square with your hands)*

***This is the roof.*** *(hands together and pointing upwards over your head)*

***This is the window.*** *(mime opening a window)*

***This is the door.*** *(mime opening a door)*

***This is my house.*** *(make a square with your hands)*

***This is the roof.*** *(hands together and pointing upwards over your head)*

***This is the wall.*** *(mime touching a wall)*

***This is the floor.*** *(look down and stamp your feet)*

Repeat again and this time ask the class to join in with the mimes.

# Module 3 – My Home

## ★ 3 Draw lines to match.

Point to the drawings and elicit the names. Explain the activity. The students look and match the missing parts of the house.

## ★ 4 Use the template to make your house. Then, talk with your friend: *This is my house.* *The (wall) is (green).*

### Before going into class

Photocopy the house template, (p. 104) one per student.

Tell the students that they are going to make a house. Show them your model. Guide them through the cutting and colouring of their templates. Go round the classroom as the students make their houses and ask questions about the colours the students have used.

Upon completion of their craftwork, the students work in pairs and talk about their houses, e.g. *The window is green.* etc Then they hand in their projects to be displayed.

## ENDING THE LESSON

(An activity to consolidate the language of the lesson.)



### FLASHCARDS (16-21)

Shuffle the flashcards and show them to the students, one at a time, without looking at them as you say, e.g. *This is the roof.* If you guess correctly, the students raise their hands and you put the flashcard aside. Otherwise, you shuffle it back into the pack. Continue playing until you have guessed all the flashcards.

### WORKBOOK (Optional)

If you wish, you can do Exs 1 and 2 from the *Workbook* during this lesson or the next one.

## Lesson 2

### Objectives

- To present pieces of furniture. To talk about location.
- To explore other subject areas: Maths.

### Language

In this lesson the students will learn to **understand**:

- *What's this?*
- *Where's the pencil?*
- *Where's (Woody)?*

In this lesson the students will learn to **use**:

- *Furniture: table, chair, bed, cupboard.*
- *It's a (table).*
- *This is my (chair). It's (red).*
- *Woody's on the (table).*
- *Woody's in the (cupboard).*

### Extra Materials

- Flashcards (22-25) for *Presentation & Practice* and the *Ending the Lesson* activity;
- clay or plasticine for Ex. 1.

## BEGINNING THE LESSON

(An activity to review the language of the previous lesson.)

Draw a half-finished sketch of a house on the board. Ask individual students to come to the board and finish the sketch by drawing *a roof, a window, a floor, a wall and a door.* Then point to the sketch of the roof and ask: *What's this?* Elicit: *This is the roof.* etc

## PRESENTATION & PRACTICE

(Activities to present and practise the vocabulary of the lesson.)

### ★ Listen, point to the furniture items and say. (TRACK 23)



### FLASHCARDS (22-25)

**Students' books closed.** Put up the flashcards on the board, one at a time. Point to the pieces of furniture (*table, chair, bed, cupboard*) and present them. The students repeat after you. Point to the pieces of furniture in random order and ask questions. Elicit the responses from different students. Demonstrate this yourself first.

e.g. Teacher: (pointing to the table) *What's this?*

Class: (It's a) *table.* etc

**Students' books open.** Say: *Open your books at page*

*thirty-six*. Write the number 36 on the board and hold up your book. Play the recording. The students listen, point and repeat.

## TAPESCRIPT

*Table, chair, bed, cupboard.*

**1** Match the furniture items to the silhouettes. Then, use clay or plasticine to make one of them. Then say: *This is my (chair). It's (red).*

Elicit the names of the pieces of furniture by pointing and asking: *What's this?* Explain the activity. The students look at the silhouettes and match them to the items.

Then tell the students to use clay or plasticine to make one of the items. Once they finish, have the students show their models to the class and say: *This is my (chair). It's (red).* etc. Make sure you display their work somewhere in the classroom.

**2** Trace. Then, say: *Woody's (on) the (table).*

**Students' books closed.** Place a pencil on a book and ask: *Where's the pencil?* Say: **On** the book. The students repeat after you. Place the pencil in the book. Ask: *Where's the pencil now?* Say: **In** the book. The students repeat after you. Ask a student to come to the front of the classroom. Give him/her the pencil and the book. Say: *In the book.* The student places the pencil in the book. Ask the rest of the class for verification. Repeat with as many students as you think is necessary.

**Students' books open.** Explain the activity. Allow the students some time to trace the items. Go round the classroom as they are tracing and ask them to name the items.

Once they finish, point to Woody sitting on the table and ask: *Where's Woody?* Say: *Woody's on the table.* The students repeat after you. Then point to Woody sitting on the chair and ask: *Where's Woody?* Elicit the response: *Woody's on the chair.* Then point to Woody in the house and ask: *Where's Woody?* Elicit: *Woody's in the house.* Finally, point to Woody sitting in the cupboard, ask and elicit the answer: *Woody's in the cupboard.*

**3** Listen and point. Then, sing. (TRACK 24)

Point to the picture of Woody in the house, mime and ask: *Where is Woody? Where is little Woody? Where is Woody? Woody, where are you?* The students repeat after you. Follow the same procedure for the rest of the song.

Play the recording. The students listen and point to the correct picture of Woody. Play the recording again. The students listen and sing along.

## TAPESCRIPT

*Where is Woody?  
Where is little Woody?  
Where is Woody?  
Woody, where are you?*

*Little Woody's in the house,  
Little Woody's in the house,  
In the house,  
In the house.*

*Where is Woody?  
Where is little Woody?  
Where is Woody?  
Woody, where are you?*

*Little Woody's on the table,  
Little Woody's on the table,  
On the table,  
On the table.*

*Where is Woody?  
Where is little Woody?  
Where is Woody?  
Woody, where are you?*

*Little Woody's on the chair,  
Little Woody's on the chair,  
On the chair,  
On the chair.*

*Where is Woody?  
Where is little Woody?  
Where is Woody?  
Woody, where are you?*

*Little Woody's in the cupboard,  
Little Woody's in the cupboard,  
In the cupboard,  
In the cupboard.*

## ENDING THE LESSON

*(Activities to consolidate the language of the lesson.)*



### FLASHCARDS (22-25)

Show the flashcards, one at a time, and ask the students to name the items. Then put only three of the four flashcards on the board. Ask the students to name the missing flashcard. Repeat the activity.

### WORKBOOK (Optional)

If you wish, you can do Exs 3-6 from the *Workbook* during this lesson or the next one.

# Module 3 – My Home

## Lesson 3

### Objectives

To listen to a story about Woody and Frosty's tree house. To develop listening comprehension skills through a dialogue.

### Language

In this lesson the students will learn to **understand**:

- *What's in your house?*
- *Who's this?*
- *What's this?*
- *Where's ... ?*

In this lesson the students will learn to **use**:

- *Hello, (Alvin).*
- *This is my (table).*
- *Where's Frosty?*
- *Frosty's in bed!*
- *Wake up, Frosty!*

### Extra Materials

- The *My Home* poster for *Presentation & Practice*;
- slips of paper with simple sketches of furniture for the *Ending the Lesson* activity.

## BEGINNING THE LESSON

(An activity to review the language of the previous lesson.)

Ask the students to name two items they have in their house. Have the students report back to the class.

e.g. Teacher: *What's in your house?*

Student 1: *(A) table (and) (a) bed. etc*

## PRESENTATION & PRACTICE

(Activities to present the story and develop students' listening skills.)



**1 Listen to the story and point to the pictures.**

(TRACK 25)



POSTER

**Students' books closed.** Use the *My Home* poster to present the story. Explain to the students, in L1 if necessary, that Woody is showing his house to Alvin. Point to Woody in the first picture and ask: *Who's this?* Elicit: *Woody*. Say as you wave: *Hello, Alvin!* The students repeat after you. Point to Alvin in the second picture and say: *Hello, Woody!* The students repeat after you. Repeat with the rest of the pictures.

**Students' books open.** Say: *Open your books at page thirty-eight.* Write the number 38 on the board and hold up your book. Point to Alvin in the first picture and ask: *Who's this?* Elicit: *Alvin*. Then point to the house and ask: *What's this?* Elicit a response: e.g. *(This is) a house!* Repeat with the remaining pictures.

Play the recording and ask the students to point to each picture in their book in turn. Show them what to do by holding up your book and pointing. Play the recording again. The students listen and repeat, chorally and/or individually.

Point to the first picture on the poster. Ask the students to complete your sentences.

e.g. Teacher: *Hello ...*  
Class: *Alvin! etc*

### Extension

Ask for a volunteer to come and point to the first picture on the poster. Encourage him/her to say the dialogue. Ask the rest of the class for verification. Repeat with different students for the rest of the story.

### TAPESCRIPT

#### Frame 1

Woody: *Hello, Alvin!*

#### Frame 2

Alvin: *Hello, Woody!*

#### Frame 3

Woody: *This is my table.*

#### Frame 4

Woody: *This is my bed.*

#### Frame 5

Alvin: *Where's Frosty?*

#### Frame 6

Woody: *Frosty's in bed!*

#### Frame 7

Woody: *Wake up, Frosty!*

Read the question at the bottom of page 39. Ask the students to draw a happy face or a sad face depending on whether they like the story or not. Ask them to tell you, in L1 if necessary, what they like most.

## ENDING THE LESSON

(An activity to consolidate the language of the lesson.)

### Before going into class

Prepare slips of paper with simple sketches of the furniture items, one for each pair of students.

Prepare slips of paper with simple sketches of the furniture items students have learned in this unit. Divide the class into pairs. Tell the students that you are moving house and they have to help you move the furniture. Give each pair a slip of paper. The students look at the picture on the slip of paper, name the piece of furniture and mime moving the piece across the room to a designated area where a supposed removal van is.

### Lesson 4

#### Objectives

To talk about animal homes.

#### Language

In this lesson the students will learn to **understand**:

- *This is a (doghouse).*
- *Animal homes: nest, basket, fish tank, doghouse*

In this lesson the students will learn to **use**:

- *Dog, fish, bird, cat*

#### Extra Materials

- Scissors, markers, paper bags for each student for Ex. 3;
- A4 sheets of paper for each student for the *Ending the Lesson* activity.

simple sketch of a *doghouse* on the board, point to it and say: *This is a doghouse*. The students repeat after you. Invite students to tell you which animal lives in it. Repeat with the rest of the animal homes.

**Students' books open.** Say: *Open your books at page forty*. Write the number 40 on the board and hold up your book. Ask the students to follow the lines and draw the homes as in the example.

### 2 Spot the mistakes.

Explain the activity. Ask the students to find and circle the mistakes. Check their answers.

#### Items to be circled:

fish, cat, bird

### 3 Make your own Pet House!

#### Before going into class

Bring in paper bags, one for each student.

Read the instructions and explain the activity. Show the students your model. Guide them through the cutting and gluing of the pet house. Draw and cut around a door frame. Then draw windows. Ask the students to draw a picture of their pet inside the house. Alternatively, they can attach a photo.

## ENDING THE LESSON

(An activity to consolidate the language of the lesson.)

Provide the students with a sheet of paper. The students think of another animal and draw it and its home. Display their work somewhere in the classroom.

### Lesson 5

#### Objectives

To consolidate the language learnt in the module.

To draw a picture of one's room.

#### Language

In this lesson the students will learn to **understand**:

- *Where's the (blue) book?*

In this lesson the students will learn to **use**:

- *(On) the (table).*
- *This is room. Look! This is my (bed).*

#### Extra Materials

- Various furniture magazines for the *Ending the Lesson* activity.

## BEGINNING THE LESSON

(An activity to review the language of the previous lesson.)

Play the dialogue from the previous lesson (Track 25). The students listen and follow in their books.

## PRESENTATION & PRACTICE

(Activities to talk about animal homes.)

### 1 Follow and find the animal homes. Then, draw them on the right sheet.

**Students' books closed.** Tell students, in L1 if necessary, that animals live in different types of homes. Draw a



# Module 3 – My Home

## BEGINNING THE LESSON

(An activity to review the language of the previous lesson.)

Draw simple sketches of furniture on the board. Elicit their names.

## PRACTICE

(Activities to consolidate furniture and parts of the house.)

### 1 Listen and tick (✓). (TRACK 26)

Point to and elicit the parts of the house. Explain the activity. The students listen and tick the items they hear. Check their answers.

**Items to be ticked:** window, door, roof

#### TAPESCRIPT

Window, door, roof.

### 2 What's next? Look and draw.

Explain the activity. Allow the students some time to complete the activity. Then, students point to and name the items. Ask the rest of the class for verification.

Students draw a bed and a chair.  
Students draw two tables.  
Students draw a house and a window.

### 3 Listen and colour. (TRACK 27)

(An activity to consolidate talking about location.)

Point to the blue book and elicit its colour. Ask: *Where's the blue book?* Elicit: *On the table.* Play the recording, twice if necessary. The students listen and colour the books.

a yellow book in the cupboard,  
a green book on the bed,  
a red book in the schoolbag.

#### TAPESCRIPT

*Where's the blue book? On the table.*

*Where's the yellow book? In the cupboard.*

*Where's the green book? On the bed.*

*Where's the red book? In the schoolbag.*

#### Extension

Divide the class into two teams. Ask students to look at the picture of Ex. 3 for a minute, then close their books. Ask questions about the location of each book. Each

correct answer gets one point. The team with the most points is the winner.

e.g. Teacher: *Where's the blue book?*  
Student 1 Team A: *On the table.*  
Teacher: *Correct! Team A gets 1 point.*  
*Where's the red book?*  
Student 1 Team B: *In the schoolbag. etc*

### 4 Portfolio: Draw a picture of your room. Present it to the class. Say: **Look! This is my (bed), ...**

(An activity to develop fine motor skills and consolidate the language of the module.)

Point to the picture and elicit the items. Then say: *This is my room! Look! This is my bed, my table and my chair.* Ask the students to draw a picture of their room and present it to the class. Make sure you display their work somewhere in the classroom. Then help them file their drawings in their *Junior Language Portfolios*.

## ENDING THE LESSON

(An activity to consolidate the language of the lesson.)

#### Before going into class

Bring in various furniture magazines.

Divide the students in groups and assign a piece of furniture (*bed, table, chair, cupboard*) to each group. Ask the groups to look through magazines and find pictures of their piece of furniture and make a collage. Make sure you display their work somewhere in the classroom.

### Lesson 6 – Our World/My World

#### Objectives

To familiarise students with fairy tale characters and their houses.

#### Language

In this lesson the students will learn to **understand**:

- UK, USA, Germany, France
- Belle, Hansel and Gretel, Pocahontas, Jack

In this lesson the students will learn to **use**:

- *Look at (Belle)'s house. Look at the (roof).*
- *(Is it) in the (cupboard)?*

#### Extra Materials

- A map of the world for Ex. 1 (Optional);
- flashcards (16-25) for the *Ending the Lesson* activity.



## BEGINNING THE LESSON

(An activity to review the language of the previous lesson.)

Ask the students to present the drawings they made in the previous lesson.

## OUR WORLD

(Activities to familiarise students with fairy tale characters and their houses.)

- 1 **Look at the pictures and draw lines to match the houses to the right fairy tale character. Then, point and say: Look at (Jack's) house. Look at the (roof).**

**Students' books open.** Say: *Open your books at page forty-four.* Write the number 44 on the board and hold up your book. Direct the students' attention to the flags and the fairy tale characters. Point to the French flag and say: *France.* If you have a map of the world, put it up on the board and show where France is. Then point to the fairy tale character holding the French flag and ask: *Who's this?* Elicit the name: *Belle.* Have a class discussion about the fairy tale in L1. If the students are not familiar with the character tell them that Belle is a character from *Beauty and the Beast.*

Repeat by pointing to the remaining flags and fairy tale characters and eliciting their names. (*Hansel and Gretel – Germany, Pocahontas – USA, Jack from Jack and the Beanstalk – UK.*)

Explain the task. Tell the students to match the characters to the houses. Once they finish, have students say whose house it is. Demonstrate this yourself first by pointing to the picture of the cottage and saying: *Look at Jack's house. Look at the roof.* Encourage the students to point to the parts of the house that they know and name them.

## MY WORLD

(Activities for the students to explore and talk about their own culture in English.)

- 2 **Look and say the name of the fairy tale.**

Point to the picture and elicit, in L1, the name of the fairy tale character (*Snegurochka*). Ask the students to tell you, in L1, what the story is about and if they like it.

- 3 **Draw your favourite fairy tale character.**

Explain the activity. Allow the students some time to

draw their favourite fairy tale character. Then they present it. Alternatively, the students can make a collage of pictures from their favourite fairy tale. You can help them write the title in English.

### Optional Activity

Ask the students to draw or find pictures of their favourite fairy tale/cartoon character and his/her house. Make sure you display their work somewhere in the classroom.

- 4 **Play the Hide the Object game.**

Tell the students they are going to play the *Hide the Object* game. Explain the game. Ask a student to leave the classroom while you hide an object. The student returns to the classroom and asks questions in order to find the object. e.g. (*Is it in the cupboard?* etc. Once he/she finds the object, the game is repeated with other students.

## ENDING THE LESSON

(An activity to consolidate the language of the module.)



### FLASHCARDS (16-25)

Hold up the flashcards, one by one, and ask the class for verification.

e.g. Teacher: (*holding roof flashcard*) *Roof.*

Student 1: *Yes.*

Teacher: (*holding cupboard flashcard*) *Table.*

Student 2: *No. etc*

### Lesson 7 – Storyland

#### Objectives

To listen to a Russian story in English. To develop listening and speaking skills.

#### Language

In this lesson the students will learn to **understand**:

- *Can they pull the turnip out?*

In this lesson the students will learn to **use**:

- *come, hold*

#### Extra Materials

- Flashcards (26-27) for *Presentation & Practice.*

# Module 3 – My Home

## BEGINNING THE LESSON

(An activity to revise the story.)

Ask the students if they remember what the previous episode of the story was about. If not ask them to go to the respective page (32) and look at the picture.

## PRESENTATION & PRACTICE

(Activities to present the tale of 'The Giant Turnip'.)

 **Listen, point to the pictures and repeat.**  
(TRACK 28)



**FLASHCARDS (26-27)**

**Students' books closed.** Put up the flashcards on the board, one at a time. Point to the items on the flashcards (*come, hold*) and present them. The students repeat after you. Mime the actions. The students name them.

**Students' books open.** Say: *Open your books at page forty-six.* Write the number 46 on the board and hold up your book. Play the recording. The students listen, point and repeat.

### TAPESCRIPT

*Come, hold.*

 **Listen to the story. (TRACK 29)**

Direct the students' attention to the picture. Point to the characters and present them. Point to the turnip and the characters and ask: *Can they pull the turnip out? Let's see!* Play the recording for the students to listen to the story. Play the recording again. The students listen and point to the characters as they are mentioned. Play the CD a third time with pauses. The students listen and repeat, chorally and/or individually.

### TAPESCRIPT

*Please help me pull out the turnip!* the old man says to his wife. *Alright, I'm coming,* she says. *So, she holds the old man. The old man holds the turnip. They pull and pull. But they can't pull the turnip out! "We need help," she says. So she calls Little Anna.*

## ENDING THE LESSON

(An activity to consolidate the language of the lesson.)

Narrate the story. The students mime it.

### Lesson 8 – Checkpoint

#### Objectives

To consolidate the language of the module.

 **1 Listen and circle. (TRACK 30)**

Elicit the items. Explain the activity. The students listen and circle the item they hear. Check the students' answers.

#### Items to be circled:

- |         |            |
|---------|------------|
| 1 roof  | 3 door     |
| 2 chair | 4 cupboard |

#### TAPESCRIPT

*One: roof*

*Two: chair*

*Three: door*

*Four: cupboard*

 **2 Draw and say where the items are.**

Elicit the names of the school items as well as the furniture. Explain the activity. The students trace the furniture. Then they point and say where the items are. Check the students' answers.

- 1 The pencil case is on the table.
- 2 The schoolbag is under the chair.
- 3 The table is in the tree house.
- 4 The schoolbag is under the table.

**Note:** The students are now ready to do Module Test 3.

## Lesson 1

### Objectives

To present and practise the names of toys.

### Language

In this lesson the students will learn to **understand**:

- *How many (planes)? Let's count!*
- *What have you got?*

In this lesson the students will learn to **use**:

- *Yes!/No!*
- *Toys: doll, ball, car, train, plane, teddy.*
- *Here's a (doll).*
- *I've got a (red teddy).*

### Extra Materials

- Flashcards (16-25) for the *Beginning the Lesson* activity;
- the *My Toys* poster for *Presentation & Practice*;
- flashcards (28-33) for Ex. 4 and the *Ending the Lesson* activity.

## BEGINNING THE LESSON

(An activity to review the language taught in the previous module.)



### FLASHCARDS (16-25)

Hold up the flashcards, one at a time, and say the word. Ask the students to answer *yes* or *no*.

e.g. *Teacher: (holding up the house flashcard) House.*  
*Student 1: Yes!*  
*Teacher: (holding up the floor flashcard) Table.*  
*Student 2: No! etc*

## PRESENTATION & PRACTICE

(Activities to present and practise toys.)

### ★ Listen, point to the toys and say. (TRACK 31)



### POSTER

**Students' books closed.** Put up the *My Toys* poster on the board. Point to the toys (*doll, ball, car, train, plane, teddy*), one at a time, and say the word. The students repeat after you. Point to the toys in random order and say: *Here's a (doll)*. Individual students name the toys.

**Students' books open.** Say: *Open your books at page forty-eight.* Write the number 48 on the board and hold up your book. Read the title and say/ elicit what it

means. Play the recording. The students listen, point to the toys and repeat. Check their pronunciation and intonation.

Point to the doll and say: *Here's a doll.* The students repeat after you. For the remaining toys, ask the students to point to a toy and say, e.g. *Here's a (ball).*

### TAPESCRIPT

*Doll, ball, car, train, plane, teddy.*



### 1 Listen to the song and circle the toys you hear. Then, sing. (TRACK 32)

Point to the boy on the poster and say: *boy.* The students repeat after you. Do the same with the girl. Then point to the train and say: *I've got a train!* The students repeat after you. Then point to the ball and encourage the students to finish your sentence: *I've got a (ball).* Repeat with the *teddy* and the *doll.* Play the recording. Ask the students to listen to the song and circle the toys they hear. Check their answers. Play the recording again, encouraging the students to sing along, while pointing to the toys they have circled.

**Items to be circled:** train, ball, teddy, doll

### TAPESCRIPT

*I've got a train,  
I've got a ball!*

*I've got a teddy,  
I've got a doll!*

*All the girls  
And all the boys*

*Have got a lot of  
Lovely toys!*

### Extension

Repeat the song without the recording. Point to the pictures on the poster and encourage the students to complete the sentences. Keep the rhythm by clapping your hands or snapping your fingers.

e.g. *Teacher: I've got a ... (pointing to the train)*  
*Class: train!*



### 2 Find the toys in the picture, count them and say: *One plane, ...*

Refer the students to the picture, point to the toys and elicit the words. Explain the activity. Point to the plane and ask: *How many planes? Let's count! One.* Repeat the question: *How many planes?* Elicit the answer: *One plane.* Repeat the procedure with the rest of the toys.

# Module 4 – My Toys

one plane  
four cars

three balls  
two trains

## 3 Look and colour the toys you've got. Then, say: *I've got a (red teddy), ...*

Refer the students to the picture, point to different toys and ask individual students to tell you what they are. Explain the activity. Ask the students to choose the toys they've got and colour them using the colours they know. Allow them some time to do the colouring. Then individual students present their toys.

*e.g. Student 1: I've got a yellow teddy bear, a red train and a yellow doll. etc*

## 4 Play the *Gotcha!* game.



### FLASHCARDS (28-33)

Explain the game. The students sit, preferably in a circle. Put the flashcards of the toys (*doll, ball, car, train, plane, teddy*) on the floor, in the middle of the circle. Choose a student and ask him/her to sit with his back to the rest of the students in the circle. The remaining students choose one of the flashcards to be the *Gotcha!* flashcard. The student then turns around and points to the flashcards as he/she names them, one by one. As soon as the *Gotcha!* flashcard is pointed to and named, the remaining students shout *Gotcha!* and the student returns to the circle, keeping the *Gotcha!* flashcard. Another player is then chosen and the game continues.

**Note:** If you wish, you can use the flashcards from the previous modules, as well.

## ENDING THE LESSON

*(An activity to consolidate the language of the lesson.)*



### FLASHCARDS (28-33)

Hand out the toy flashcards to different students. Ask each student: *What have you got?* Encourage them to answer: *I've got a (ball)*. Repeat the activity so that all the students participate.

### WORKBOOK (Optional)

If you wish, you can do Exs 1 and 2 from the *Workbook* during this lesson or the next one.

## Lesson 2

### Objectives

To present and practise numbers 6-10. To consolidate numbers 1-5. To explore other subject areas: Maths.

### Language

In this lesson the students will learn to **understand**:

- *Count six pencils.*
- *What is it? Is it a train?*

In this lesson the students will learn to **use**:

- *Numbers 1-10.*
- *(Three) and (three) is (six).*
- *I've got a ...*

### Extra Materials

- Flashcards (28-33) for the *Beginning the Lesson* activity;
- photocopies for the finger puppets templates (pp. 105 - 107) for each student for Ex. 3.

## BEGINNING THE LESSON

*(An activity to review toys.)*



### FLASHCARDS (28-33)

Put the flashcards 28-33 in a pack. Go around the classroom showing individual students two or three toys each and asking them to name them.

## PRESENTATION & PRACTICE

*(Activities to present and practise numbers 6-10.)*



### Listen and say the numbers. (TRACK 33)

**Students' books closed.** Collect ten pencils/pens from the students. Hold the pencils up, one by one, and count them out loud. Ask the students to join in. Then invite individual students to come to the front of the classroom, take your role and repeat the activity. Finally, say the numbers at random and ask the students to count the pencils according to the corresponding number.

*e.g. Teacher: Count six pencils.*

*Student 1: One, two, three, four, five, six pencils. etc*

**Students' books open.** Say: *Open your books at page fifty.* Write the number 50 on the board and hold up your book. Play the recording. The students listen, point to the numbers and repeat.

## TAPESCRIPT

*Six, seven, eight, nine, ten.*

### 1 Count and find the toys. Then, say: *I've got a (train).*

Write the following on the board:  $3 + 5 = \dots$ . Say: *Three and five is ...*. Elicit the answer: *eight*. Write the number on the board and ask the students to do the same in the first speech bubble. Ask the students to do the rest of the sums and write the numbers. Check around the classroom, providing any necessary help. Ask students to tell you the sums.

*e.g. Student 1: Three and three is six.  
Student 2: Nine and one is ten.  
Student 3: Five and two is seven.  
Student 4: Three and six is nine.*

Then ask students to find the corresponding toy each child (1-5) has got.

Point to the first child and say: *I've got a train*. The students repeat after you. Follow the same procedure for all the children in the pictures, inviting the students to repeat after you.

- |                     |                     |
|---------------------|---------------------|
| 2 I've got a teddy. | 4 I've got a plane. |
| 3 I've got a doll.  | 5 I've got a ball.  |

### Memory game (Optional)

Ask the students to look at the toys for one minute before they close their books. Say a number. The students name the corresponding toy.

*e.g. Teacher: Ten!  
Student 1: Doll! etc*

### 2 Listen and join the dots. Then say what it is. (TRACK 34)

Point to the incomplete picture and ask: *What is it? Is it a train?* Invite guesses as to what it is. Explain the activity. Play the recording, twice if necessary. The students listen and join the dots. Point to the completed picture and ask again: *What is it?* Elicit: *(It's) a plane.*

## TAPESCRIPT

*One, eight, six, four, nine, seven, two, ten, three, five, one.*

### Extension

Allow the students time to colour the plane. Colour your plane, hold up your book and say: *I've got a (red) plane*. Ask individual students to hold up their book and present their plane to the rest of the class.

### 3 Make the number finger puppets and sing. (TRACK 35)

#### Before going into class

Photocopy the finger puppets templates and give one photocopy to each student. The students make the finger puppets and put them on their fingers.

Refer the students to the picture. Show them your model and ask the students to cut out and colour their finger puppets. Provide any necessary help.

Put on your finger puppets and say: *Count with me!* The students do the same and repeat after you. Then say: *Count with me to ten!* The students repeat after you. Say the numbers as you wiggle the corresponding fingers. The students do the same. Play the recording. The students listen and do the actions. Play the recording again. The students sing and do the actions.

## TAPESCRIPT

*Count with me,  
Count with me to ten:  
One, two, three, four, five, six,  
Seven, eight, nine and ten!*

### Extension

Ask the students, in pairs, to show a finger puppet to their partner and he/she has to say which number is shown each time. Monitor the activity around the classroom.

## ENDING THE LESSON

*(An activity to review numbers 1-10.)*

Ask the students to choose a number from 1-10. Ask them to write it on a piece of paper and decorate their paper with toys denoting that number, e.g.



# Module 4 – My Toys

Display their work grouping them by number, i.e. all the 1's are together, etc.

## WORKBOOK (Optional)

If you wish, you can do Exs 3, 4 and 5 from the *Workbook* during this lesson or the next one.

### Lesson 3

#### Objectives

To listen to a story about the characters playing with their toys. To develop listening comprehension skills through a dialogue.

#### Language

In this lesson the students will learn to **understand**:

- *Let's play!*

In this lesson the students will learn to **use**:

- *Where's the ball?*
- *It's in the tree!*
- *I've got a (doll)!*

#### Extra Materials

- A4 sheets of paper for each student for the *Beginning the Lesson* activity;
- the *My Toys* poster for *Presentation & Practice*.

## BEGINNING THE LESSON

(An activity to review numbers 1-10.)

Provide each student with a sheet of paper. Ask them to draw outlines of their hands on it and colour them in. Write the numbers 1-10 on the board. Ask the students to write the numbers, in sequence, above each finger. Then they present their drawings to the class.

## PRESENTATION & PRACTICE

(Activities to present the story and develop students' listening skills.)

### 1 Listen to the story and point to the pictures. (TRACK 36)



#### POSTER

**Students' books closed.** Use the *My Toys* poster to present the story. Explain to the students, in L1 if necessary, that the characters have got a lot of toys and want to play. Point to the toys in the first picture and elicit their names. Then say: *Let's play!* The students repeat after you. Point

to Frosty in the second picture and say: *Lovely toys!* The students repeat after you. Repeat with the rest of the pictures.

**Students' books open.** Say: *Open your books at page fifty-two.* Write the number 52 on the board and hold up your book. Ask students to identify the characters and the toys they know.

e.g. Student: (pointing to Alvin in Frame 1) *(This is) Alvin! etc*

Play the recording and ask the students to point to each picture in their book in turn. Show them what to do by holding up your book and pointing. Play the recording again. The students listen and repeat, chorally and/or individually.

Point to the first picture on the poster. Ask the students to complete your sentences.

e.g. Teacher: *Let's ...*  
Class: *play! etc*

#### Extension

Ask for a volunteer to come and point to the first picture on the poster. Encourage him/her to say the dialogue. Ask the rest of the class for verification. Repeat with different students for the rest of the story.

#### TAPESCRIPT

##### Frame 1

Alvin: *Let's play!*

##### Frame 2

Frosty: *Lovely toys!*

##### Frame 3

Erlina: *I've got a doll!*

##### Frame 4

Woody: *I've got a ball!*

##### Frame 5

Woody: *Let's play!*

##### Frame 6

Frosty: *Where's the ball?*

Alvin: *It's in the tree.*

##### Frame 7

Frosty: *Look! I've got a plane!*

Read the question at the bottom of page 53. Ask the students to draw a happy face or a sad face, depending on whether they like the story or not. Ask them to tell you, in L1 if necessary, what they like most.



## ENDING THE LESSON

(An activity to consolidate the language of the lesson.)

Ask individual students to come to the board, say: *I've got a ...* and mime a toy. The rest of the class has to guess what it is.

e.g. Student 1: *I've got a ... (mimes flying)*

Class: *plane! etc*

**Note:** For the next lesson, ask each student to bring an empty coffee can to class.

### Lesson 4

#### Objectives

To talk about recycling, to talk about how we can recycle an empty coffee can by using it for multiple purposes.

#### Language

In this lesson the students will learn to **understand**:

- *coffee can, money box, marbles*

In this lesson the students will learn to **use**:

- *recycle glass, paper, aluminium*

#### Extra Materials

- An empty coffee can for Ex. 2;
- A4 sheets of paper for each student for the *Ending the Lesson* activity.

## BEGINNING THE LESSON

(An activity to revise the dialogue.)

Play the dialogue from the previous lesson (Track 36). The students listen and follow in their books.

## PRESENTATION & PRACTICE

(Activities to talk about recycling.)

### 1 Draw lines to match. Then, colour the pictures.

**Students' books closed.** Draw a simple sketch of the recycling symbol on the board. Point to it and say: *Recycle*. The students repeat after you. Have a class discussion, in L1 if necessary, about recycling and what we can recycle. During this stage present the words *glass, paper* and *aluminium*.

**Students' books open.** Say: *Open your books at page fifty-four*. Write the number 54 on the board and hold

up your book. Refer the students to the picture and explain the activity. Allow the students some time to draw lines from the items to the right recycling bin. Check the students' answers.

### 2 Colour the pictures.

#### Before going into class

Have an empty coffee can ready to use.

Explain the activity. Hold up the *coffee can* and say the word for it. The students repeat after you. Tell the students that instead of throwing them away, we can use empty coffee cans for multiple purposes. Point to the pictures and explain to the students that we can use an empty *coffee can* to keep *marbles* in it, or we can use it as a *money box* to save money, or as a *pencil holder*. Ask the students to colour the coffee cans as they wish.

**Note:** It is important that the students learn the importance of recycling. The students should be encouraged to go home and try and reuse cans to make other things. This depends to a great extent on how enthusiastic and eager we teachers are when we present this activity. If the students see that we love things made out of recycled cans, they will do it even if it is just to please us.

### 3 Play the Coffee Can game.

Collect five empty coffee cans from the students and write numbers 1-5 on them. Time permitting, ask the students to decorate them. Put the cans in a row and use a rubber to demonstrate the game. Stand opposite the coffee cans and say the number (1-5) you will be aiming at, e.g. 2. Try to throw the rubber in can Number 2. If the rubber gets into the can, you get 1 point and you can play again. If the rubber falls out of the can, you miss a turn and it is the other player's turn to play. The students play the game in two teams. The team with the most correct shots (points) wins the game.

**Note:** Instead of a rubber, you can use other objects as well, such as a coin, a marble, a button, etc.

## ENDING THE LESSON

(An activity to consolidate the language of the lesson.)

Provide the students with a sheet of paper. The students think of other ways of reusing a coffee can (e.g. a flower pot) and draw a picture. Display their work somewhere in the classroom.



# Module 4 – My Toys

## Lesson 5

### Objectives

To consolidate the language learnt in the module.  
To distinguish between big and small items. To draw a picture of a toy.

### Language

In this lesson the students will learn to **understand**:

- How many?

In this lesson the students will learn to **use**:

- big/small
- The (big ball is in the (big) box.
- This is my favourite toy. It's a ...

### Extra Materials

- Flashcards (28-33) for the *Beginning the Lesson* activity.

## BEGINNING THE LESSON

(An activity to revise the language of the previous lesson.)



### FLASHCARDS (28-33)

Put up the toy flashcards on the board. Ask a student to come to the board. Name a toy. Ask the student to point to the corresponding flashcard. Ask the rest of the class for verification. Repeat with as many students as you think is necessary.

## PRACTICE

(Activities to consolidate toys and size.)



### 1 Listen and colour. (TRACK 37)

Say: *Open your books at page fifty-six.* Write the number 56 on the board and hold up your book. Refer the students to the picture and explain the activity. Elicit the names of the toys. Play the recording, twice if necessary. The students listen and colour the items. Check their answers.

a red teddy      a blue plane      a green train  
a pink doll      a yellow ball

### TAPESCRIPT

Woman: Can you see teddy?  
Boy: The teddy? Yes. I can see the teddy.  
Woman: Colour the teddy red.  
Boy: A red teddy. OK.  
Woman: Can you see doll?  
Boy: The doll? Yes. I can see the doll. What colour is the doll?

Woman: Colour the doll pink.  
Boy: The doll is pink. OK.  
Woman: Colour the plane blue.  
Boy: The plane? Blue?  
Woman: Yes. Colour the plane blue.  
Boy: A blue plane. OK.  
Boy: What colour is the ball?  
Woman: The ball is yellow.  
Boy: A yellow ball. OK.  
Woman: Can you see train?  
Boy: Yes. What colour is the train?  
Woman: Green. Colour the train green.  
Boy: The train is green. OK.



### 2 Count and write the number.

Explain the activity. Allow the students some time to complete the activity. Check the students' answers.

A 6      B 10      C 4



### 3 Put the big toys into the big toy box and the small toys into the small toy box. Then, say: *The (big ball) is in the (big box).*

Draw a big and a small ball on the board. While you are doing this, say: *Look, a big ball. Look, a small ball.* Emphasise the words *big* and *small*, and ask the students to repeat after you. Then ask the students to draw big and small balls in the air, according to your instructions.

Explain the activity. The students have to put the big toys in the big box and the small toys in the small box. Allow them time to complete the activity. Then point to the picture of the big teddy and say: *a big teddy*. Point to the arrow and follow the course of the teddy into the big box. Say: *The big teddy is in the big box*. The students repeat after you. Invite individual students to say similar sentences for the rest of the toys.

*The small teddy is in the small box.*  
*The big doll is in the big box.*  
*The small doll is in the small box.*  
*The big train is in the big box.*  
*The small train is in the small box.*  
*The big ball is in the big box.*  
*The small ball is in the small box.*



### 4 Portfolio: Draw a picture of your favourite toy. Present it to your class: *This is my favourite toy. It's a (teddy).*

(An activity to consolidate the language of the module.)

Point to the picture and elicit the toy. Then say: *This is my favourite toy. It's a teddy.* Ask the students to draw a picture of their favourite toy and present it to the

class. Make sure you display their work somewhere in the classroom. Then help them file their drawings in their *Junior Language Portfolios*.

## ENDING THE LESSON

(An activity to consolidate the language of the lesson.)

Ask a student to come to the board. Say: *A big ball.* The student draws a big ball on the board. Ask the rest of the class for verification. Repeat with as many students as you think is necessary.

### WORKBOOK (Optional)

If you wish, you can do Exs 6 and 7 from the *Workbook* during this lesson or the next one.

### Lesson 6 – Our World/My World

#### Objectives

To familiarise students with British, Chinese and Russian culture. To talk about popular toys in the UK, China and Russia.

#### Language

In this lesson the students will learn to **understand**:

- *UK, China, Russia*
- *toys (yo-yo, Matryoshka)*

In this lesson the students will learn to **use**:

- *(Three) and (two) is (five). (Five) is (blue)!*
- *I've got a big car. Kelly's got a small car.*

#### Extra Materials

- A map of the world for Ex. 1 (Optional);
- A4 sheets of paper for each student for the *Ending the Lesson* activity.

## BEGINNING THE LESSON

(An activity to review the language of the previous lesson.)

Ask the students to present the drawings they made in the previous lesson.

## OUR WORLD

(Activities to familiarise students with aspects of British and Chinese culture.)

- 1 **Look at popular toys from the UK and China. Then, circle the odd one out.**

**Students' books closed.** Ask the students, in L1 if necessary,

which toys are the most popular in their country. Explain to them that today they are going to learn about popular toys in the UK and China and talk about popular toys in their country.

**Students' books open.** Say: *Open your books at page fifty-eight.* Write the number 58 on the board and hold up your book. Point to the British flag and say: *UK.* If you have a map of the world, put it up on the board and show where the UK is. Repeat the same procedure with the flag of China. Point to the first picture and elicit the toy (*teddy*). Point to the second picture and elicit that it is a *yo-yo*.

Point to the groups of pictures below. Ask the students to look carefully at each group of toys and circle the odd one out.

**Items to be circled:** The 2<sup>nd</sup> teddy, the 3<sup>rd</sup> yo-yo, the 4<sup>th</sup> plane.

## MY WORLD

(Activities for the students to explore and talk about their own culture in English.)

- 2 **Draw your favourite toy.**

Explain the activity. Allow the students some time to draw their favourite toy. Then students present them. Display the students' work somewhere in the classroom.

- 3 **Count and colour. Then, say: (Three) and (two) is (five). (Five) is (blue)!**

Point to the picture of the train and the sums. Tell the students to calculate the sums and colour each part of the train according to the corresponding number deriving from the sum. Then point to each sum and say: *e.g. Three and two is five. Five is blue! etc.*

Four and four is eight. Eight is yellow.  
 Four and three is seven. Seven is green.  
 Five and five is ten. Ten is pink.  
 Five and four is nine. Nine is orange.  
 Four and two is six. Six is red.

## ENDING THE LESSON

(An activity to consolidate the language of the lesson.)

The students work in pairs. Provide each student with a sheet of paper. Hand out a toy flashcard to each pair and ask them to draw the item given. One draws a big toy and the other draws a small toy, *e.g. a small car and a big car*. Invite the students to tell you about their pictures.

# Module 4 – My Toys

e.g. Student 1: *I've got a big car. Kelly's got a small car. etc*

## Lesson 7 – Storyland

### Objectives

To listen to a Russian story in English. To develop listening and speaking skills.

### Language

In this lesson the students will learn to **understand**:

- *Can they pull the turnip out?*

In this lesson the students will learn to **use**:

- *pull, turnip*

### Extra Materials

- None.

## BEGINNING THE LESSON

*(An activity to revise the story.)*

Ask the students if they remember what the previous episode of the story was about. If not, ask them to go to the respective page (46) and look at the picture.

## PRESENTATION & PRACTICE

*(Activities to present the tale of 'The Giant Turnip'.)*



### Listen to the story. (TRACK 38)

**Students' books open.** Say: *Open your books at page sixty.* Write the number 60 on the board and hold up your book. Direct the students' attention to the picture. Point to the characters and elicit their names. Point to the turnip and the characters and ask: *Can they pull the turnip out? Let's see!* Play the recording for the students to listen to the story. Play the recording again. The students listen and point to the characters as they are mentioned. Play the CD a third time with pauses. The students listen and repeat, chorally and/or individually.

### TAPESCRIPT

*"Alright. I'm coming," she says. So, Little Anna holds the old woman. The old woman holds the old man. The old man holds the turnip. They pull and pull. But they can't pull the turnip out! "We need help," says Little Anna. So she calls the dog.*

## ENDING THE LESSON

*(An activity to consolidate the language of the lesson.)*

Narrate the story. The students mime it.

## Lesson 8 – Checkpoint

### Objectives

To consolidate the language of the module.



### 1 What are they? Look, point and say.

Explain the activity. The students look at the pictures and name the toys. Ask the rest of the class for verification.



### 2 Write the numbers.

If you wish, revise numbers 1-10. Explain the activity. The students count and write the correct number. Check the students' answers.

**A 9      B 6      C 8**

**Note:** The students are now ready to do Module Test 4.

## Lesson 1

### Objectives

To present and practise parts of the face.

### Language

In this lesson the students will learn to **understand**:

- *What's this?*
- *Touch your eyes.*
- *How many eyes?*
- *What colour is it?*

In this lesson the students will learn to **use**:

- *Parts of the face: nose, hair, ears, eyes, mouth, tongue.*
- *He's got (one big eye).*
- *Look at me! I've got (five big eyes and one big mouth).*

### Extra Materials

- Toys or pictures of toys for the *Beginning the Lesson* activity;
- the *My Face* poster for *Presentation & Practice*;
- paper plates for Ex. 4, one for each student;
- A4 sheets of paper for each student for Ex. 2 (*Extension*) and the *Ending the Lesson* activity.

## BEGINNING THE LESSON

(An activity to revise the language from the previous module.)

Before the lesson, hide real toys (or pictures of toys) in the classroom. Ask the students to look around the classroom and see if they can find them. Once they do, they show the toy to the class and name it.

## PRESENTATION & PRACTICE

(Activities to present and practise the vocabulary of the lesson.)

 **Listen, point to the parts of the face and say.**  
(TRACK 39)



POSTER

**Students' books closed.** Put up the *My Face* poster on the board. Point to the parts of the face (*nose, hair, ears, eyes, mouth, tongue*), one at a time, and present them. The students repeat after you. Then point to the different parts of the face in random order and ask questions. Elicit responses from the students. Demonstrate this yourself first.

e.g. *Teacher: (pointing to the nose) What's this?*  
*Class: (It's a) nose. etc*

**Students' books open.** Say: *Open your books at page sixty-two.* Write the number 62 on the board and hold up your book. Play the recording. The students listen, point and repeat.

### TAPESCRIPT

*Nose, hair, ears, eyes, mouth, tongue.*



**1 Listen and point. Then, sing and do.**  
(TRACK 40)

Elicit the names of the different parts of the face by pointing and asking: *What's this?* Pre-teach the word *touch*. Touch your nose with your finger and say: *Touch your nose.* The students mime the action and repeat after you. Now pull your tongue out and say: *Pull your tongue out.* The students mime the action and repeat after you. Explain the activity. Play the recording. The students listen, and do the actions.

Play the recording again. The students listen, point and sing along.

### TAPESCRIPT

*Touch your nose,  
Touch your hair,  
Touch your ears,  
There and there!*

*Touch your eyes,  
Touch your mouth,  
Pull your tongue  
Right out!*



**2 Find the parts of the face in the picture.**  
**Then, play the Touch game.**

Tell the students to look at the pictures in their books. Explain the activity. The students find the items in the picture and point to the different parts of the face. Then play the *Touch* game.

e.g. *Teacher: Touch your eyes!*  
*Students: (touch their eyes) etc*

### Extension

Provide each student with a sheet of paper. Draw an oval shape on the board. Say: *face*. Ask the students to copy it onto their piece of paper and hand it to the student on their right. Ask the students to draw a nose on the face and pass it on to the student on their right. Continue with the *hair, eyes, ears, mouth* and *tongue*. When they have finished, collect the faces and show them to the class.

# Module 5 – My Face

## ★ 3 Listen and number. Then, point and say: *He's/She's got ...* . (TRACK 41)

Explain the listening activity. Tell the students they are going to listen and number the characters. Point to the first monster and ask: *How many eyes?* Elicit the answer: *One*. Point to his hair and ask: *What colour is it?* Elicit the answer: *Orange*. Follow the same procedure with the rest of the monsters. Play the recording as many times as you feel is necessary to do the task. Check the students' answers.

Then have the students describe the monsters. During this stage, draw students' attention to the use of *he* for men and *she* for women.

2 4 3 1

### TAPESCRIPT

**One:** *I've got green hair and three eyes.*

**Two:** *I've got one eye and one big mouth.*

**Three:** *I've got three eyes and four ears.*

**Four:** *I've got pink hair and four eyes.*

## ★ 4 Make a monster mask. Then, say: *Look at me! I've got ...* .

### Before going into class

Bring in paper plates, one per student.

Tell the students that they are going to make a monster mask. Show them your model and hand out the paper plates. Guide the students through the cutting and colouring of their masks. Go around the classroom while the students make their masks, point to the parts of the face and ask the students to name them.

Upon completion of their masks, the students hold their masks over their faces and describe them. Demonstrate this yourself first, e.g. *Look at me! I've got five big eyes and one big mouth*. Then they hand in their masks to be displayed.

## ENDING THE LESSON

(An activity to consolidate the language of the lesson.)

Provide the students with a sheet of paper. Ask students to choose a facial feature (e.g. *nose*). The students draw and colour as many different shapes and sizes of noses, hair, mouths, etc., as they can think of. Go around the classroom providing any necessary help. Display their work somewhere in the classroom.

## WORKBOOK (Optional)

If you wish, you can do Exs 1 and 2 from the *Workbook* during this lesson or the next one.

### Lesson 2

#### Objectives

To talk about how to keep clean. To explore other subject areas: Health and Safety.

#### Language

In this lesson the students will learn to **understand**:

- *Woody is dirty.*
- *shampoo, brush, soap, toothpaste*
- *Now Woody is clean.*
- *What's this?*

In this lesson the students will learn to **use**:

- *wash your hands, wash your face, brush your teeth, brush your hair*
- *It's a/an... .*
- *(It's) orange.*

#### Extra Materials

- Flashcards (40-43) for *Presentation & Practice* and the *Ending the Lesson* activity;
- a scarf and photocopies (pp. 108 - 110) of the ears, mouth, eyes and nose templates for Ex. 2.

## BEGINNING THE LESSON

(An activity to revise the language of the previous lesson.)

Ask a pair of students to come to the board. One student names a part of the face and the other touches the corresponding part. Ask the rest of the class for verification. Resume the activity with as many pairs as you think is necessary.

## PRESENTATION & PRACTICE

(Activities to present and practise the vocabulary of the lesson.)

## ★ Listen, point to the actions and say. (TRACK 42)



### FLASHCARDS (40-43)

**Students' books closed.** Put up the flashcards (40-43) on the board, one at a time. Point to the actions (*wash your hands, wash your face, brush your teeth, brush your hair*), one at a time, and present them. The students repeat after you.



Hand out the flashcards to various students. Ask the students to come to the board, one at a time, show their flashcard and say the corresponding phrase or action. Ask the rest of the class for verification.

**Students' books open.** Say: *Open your books at page sixty-four.* Write the number 64 on the board and hold up your book. Play the recording. The students listen, point and repeat.

## TAPESCRIPT

*Wash your hands, wash your face, brush your teeth, brush your hair.*

**1** Look at the pictures. Tell Woody what to do to get clean! Say: **(Wash) your (hair).**

Point to the picture of Woody and say: *Woody is dirty.* Have the students tell him what to do to get clean. Point to the shampoo in the picture and elicit the action: *Wash your hair.* Next, point to the brush and elicit: *Brush your hair.* Point to the soap and elicit: *Wash your hands/face.* Finally, point to the toothpaste and elicit: *Brush your teeth.* Say: *Now Woody is clean.*

**2** Play the *Make a Monster* game.

### Before going into class

Photocopy and cut out the templates of the nose, eyes, ears and mouth.

Tell the students they are going to play the *Make a Monster* game. Draw a large circle on the board to represent the face. Cut out the ears, mouth, eyes and nose. Show the students the cutouts of the ears and elicit the corresponding word. Stick the cutouts on the sides of the circle. Repeat with the remaining cutouts.

Explain the game. Tell the class that they are going to stick the cutouts on the circle to form a face, but they are going to do this blindfolded. Choose a student to come to the board. Tie a scarf over his/her eyes. Remove the cutouts from the board and give him/her one of them. Ask: *What's this?* Elicit: *It's a/an ...*. Tell the student to stick it on the board in the correct place. Remove the blindfold so the student can see where he/she has placed the cutout. Repeat with another student until all the cutouts have been placed and a 'funny' face has emerged.

**3** Listen and point. Then, sing and do. (TRACK 43)

Point to the actions, one at a time, and elicit: *wash your hands, wash your face, brush your teeth, brush your hair.* The students repeat after you.

Play the recording. The students listen and point to the actions. Play the recording again. The students mime the actions as they sing along.

## TAPESCRIPT

*Wash your hands  
Up and down, up and down.  
Wash your hands  
Round and round, round and round.  
Wash your hands up and down,  
Wash your hands round and round,  
Wash your hands round and round like this!*

*Wash your face  
Up and down, up and down.  
Wash your face  
Round and round, round and round.  
Wash your face up and down,  
Wash your face round and round,  
Wash your face round and round like this!*

*Brush your teeth  
Up and down, up and down.  
Brush your teeth  
Round and round, round and round.  
Brush your teeth up and down,  
Brush your teeth round and round,  
Brush your teeth round and round like this!*

*Brush your hair  
Up and down, up and down.  
Brush your hair  
Round and round, round and round.  
Brush your hair up and down,  
Brush your hair round and round,  
Brush your hair round and round like this!*

## Extension

Mime one of the actions. Ask students to guess.

e.g. Teacher: *(mimes brushing teeth)*  
Class: *Brush your teeth! etc*

## ENDING THE LESSON

*(An activity to consolidate the language of the lesson.)*



### FLASHCARDS (40-43)

Hand out the flashcards to students. Play the song again. While the music is playing, students pass their flashcard on to the next student. When you pause the music, each student who is holding a flashcard has to name the action or pay a forfeit, such as sing a song, perform an action, etc.

# Module 5 – My Face

## WORKBOOK (Optional)

If you wish, you can do Exs 3 and 4 from the *Workbook* during this lesson or the next one.

### Lesson 3

#### Objectives

To listen to a story about Frosty and Woody meeting Little Red Riding Hood and the Big Bad Wolf. To develop listening comprehension skills through a dialogue.

#### Language

In this lesson the students will learn to **understand**:

- *Little Red Riding Hood, Big Bad Wolf*
- *Who's this?*
- *What's this?*

In this lesson the students will learn to **use**:

- *Hello!/Bye!*
- *Lovely flowers!*
- *Thank you!*
- *You've got big eyes!*
- *Smile!*

#### Extra Materials

- Flashcards (40-43) for the *Beginning the Lesson* activity;
- the *My Face* poster for *Presentation & Practice*.

**Students' books closed.** Use the *My Face* poster to present the story. Explain to the students, in L1 if necessary, that Woody and Frosty are going to meet Little Red Riding Hood and the Big Bad Wolf. Invite the students to tell you what they remember from the story. Point to Woody in the first picture and ask: *Who's this?* Elicit: *Woody*. Say as you wave: *Hello!* The students repeat after you. Point to the flowers in the second picture and say: *Lovely flowers!* The students repeat after you. Repeat with the rest of the pictures.

**Students' books open.** Say: *Open your books at page sixty-six.* Write the number 66 on the board and hold up your book. Tell the class to look at the story and talk about it with them.

Play the recording and ask the students to point to each picture in their book in turn. Show them what to do by holding up your book and pointing. Play the recording again. The students listen and repeat, chorally and/or individually.

Point to the first picture on the poster. Ask the students to complete your sentences.

e.g. Teacher: *Lovely...*

Student 1: *flowers! etc*

#### Extension

Ask for a volunteer to come and point to the first picture on the poster. Encourage him/her to say the dialogue. Ask the rest of the class for verification. Repeat with different students for the rest of the story.

#### TAPESCRIPT

##### Frame 1

Woody: *Hello!*

Girl: *Hello!*

##### Frame 2

Frosty: *Lovely flowers!*

Girl: *Thank you!*

##### Frame 3

Frosty: *Bye!*

##### Frame 4

Woody: *You've got big eyes!*

##### Frame 5

Frosty: *You've got big ears!*

##### Frame 6

Woody: *You've got big teeth!*

##### Frame 7

Frosty: *Smile!*

Read the question at the bottom of page 67. Ask the students to draw a happy face or a sad face

## BEGINNING THE LESSON

(An activity to revise the language from the previous lesson.)



### FLASHCARDS (40-43)

Hold up a flashcard (*wash your hands, wash your face, brush your teeth, brush your hair*) and partially cover it with a piece of paper. Invite the students to guess what's on the flashcard.

## PRESENTATION & PRACTICE

(Activities to present the story and develop students' listening skills.)



**1 Listen to the story and point to the pictures.**

(TRACK 44)



### POSTER



depending on whether they like the story or not. Ask them to tell you, in L1 if necessary, what they like most.

## ENDING THE LESSON

(An activity to consolidate the language of the lesson.)

Ask a student to be the 'photographer'. He/She goes around 'taking pictures'. Ask him/her to say *Smile!* before he/she takes the picture. Alternatively, you can use a real camera.

### Workbook (Optional)

If you wish, you can do Ex. 5 from the *Workbook* during this lesson or the next one.

### Lesson 4

#### Objectives

To identify animals according to their facial characteristics.

#### Language

In this lesson the students will learn to **understand**:

- *This is a (cat). It's got (small eyes).*

In this lesson the students will learn to **use**:

- *cat, dog*

#### Extra Materials

- Pictures of different animals for Ex. 3.

## BEGINNING THE LESSON

(An activity to revise the dialogue from the previous lesson.)

Play the dialogue from the previous lesson (Track 44). The students listen and follow in their books.

## PRESENTATION & PRACTICE

(Activities to talk about animal parts of face.)

### 1 Look at the pictures and circle the correct parts of their face.

**Students' books closed.** Draw a simple sketch of a cat on the board. Point to it and say: *This is a cat.* The students repeat after you. Elicit the cat's parts of the face: *big eyes, small ears, small nose.* Repeat with a sketch of a dog.

**Students' books open.** Say: *Open your books at page sixty-eight.* Write the number 68 on the board and hold up your book. Ask the students to circle the parts of the face that pertain to each animal. Check the students' answers.

**Cat:** 1 2nd picture 2 1st picture 3 1st picture  
**Dog:** 1 2nd picture 2 1st picture 3 1st picture

### 2 Colour. Then, find their pair.

Explain the activity. Allow the students some time to colour the parts of the body and match them to their pairs. If you wish, you can ask the students to identify the animals in L1 (*rabbit, elephant, mouse, cat*). Check the students' answers.

### 3 Make your own animal.

#### Before going into class

Bring in pictures of different animals.

Have a brief class discussion, in L1 if necessary, about animal body parts. Refer the students to the picture in Ex. 3. The students, either on their own or in pairs/groups, make their own unusual animal using the picture as a guide. Alternatively, students are given pictures and make an animal collage. Go around the classroom providing any necessary help. Make sure you display their work somewhere in the classroom.

## ENDING THE LESSON

(An activity to consolidate the language of the lesson.)

Do a class survey as to which animal (cat or dog) is the most popular.

### Lesson 5

#### Objectives

To consolidate the language learnt in the module.  
 To draw a picture of Mr/Miss Potato.

#### Language

In this lesson the students will learn to **understand**:

- *What colour?*
- *What's this?*

In this lesson the students will learn to **use**:

- *He's got (yellow hair).*
- *Look at (Miss) Potato. (She)'s got (red hair).*

#### Extra Materials

- A4 sheets of paper for each student for Ex. 3.

# Module 5 – My Face

## BEGINNING THE LESSON

(An activity to review the language from the previous lesson.)

Name a part of the face. Ask the students to point to it and repeat.

e.g. Teacher: Hair!

Students: (pointing to their hair) Hair! etc

## PRACTICE

(Activities to consolidate parts of a face.)

### 1 Find the missing pieces.

Say: Open your books at page seventy. Write the number 70 on the board and hold up your book. Refer the students to the pictures and explain the activity. Allow the students some time to find the missing parts of the monsters. Check their answers.

1 a    2 b    3 e    4 c    5 d

### 2 Listen and colour. Then, say: He's got yellow hair, ... (TRACK 45)

Point to the picture. Point to the shoes and ask: What colour? Elicit: Blue. Revise the parts of the face by asking: What's this? Play the recording, twice if necessary. The students listen and colour in the picture. Once they finish, they describe the picture, e.g. He's got yellow hair ... etc.

yellow hair

red ears

pink hands

blue eyes

green nose

## TAPESCRIPT

Colour the hair yellow.

Colour the eyes blue.

Colour the ears red.

Colour the nose green.

Colour the hands pink.

## Extension

Divide the class into two teams. Ask students to look at the picture in Ex. 2 for a minute and then close their books. Ask questions about the colour of each body part. Each correct answer gets one point. The team with the most points is the winner.

e.g. Teacher: What colour is his hair?

Student 1 Team A: Yellow.

Teacher: Correct! Team A gets 1 point.

What colour is his nose?

Student 1 Team B: Blue.

Teacher: Wrong! etc

### 3 Portfolio: Draw a picture of Mr/Miss Potato. Present them to the class. Say: Look at Mr/Miss Potato. He/she's got...

(An activity to develop fine motor skills and consolidate the language of the module.)

Point to the picture of Mr Potato. Then say: This is Mr Potato! Provide each student with a sheet of paper. Ask the students to draw a similar picture of either Mr or Miss Potato and present it to the class. Have them present their drawing to the class and describe it, e.g. Look at Miss Potato. She's got red hair. etc. Make sure you display their work somewhere in the classroom. Then help them file their drawings in their Junior Language Portfolios.

## ENDING THE LESSON

(An activity to consolidate the language of the lesson.)

Draw a simple sketch of Mr Potato on the board. Ask a student to come to the board. Ask him/her to colour a part of its face. Ask the rest of the class for verification. Repeat with some more until Mr Potato is coloured.

## WORKBOOK (Optional)

If you wish, you can do Ex. 6 from the Workbook during this lesson or the next one.

## Lesson 6 – Our World/My World

### Objectives

To familiarise students with British, American and Russian culture. To talk about cartoon characters in the UK, USA and Russia.

### Language

In this lesson the students will learn to **understand**:

- UK, USA, Russia
- Stitch, Mickey Mouse, Pinocchio, Lightning McQueen from Cars, Wallace and Gromit

In this lesson the students will learn to **use**:

- He's got (a big nose).

### Extra Materials

- A map of the world for Ex. 1 (Optional);
- A4 sheets of paper for each student for Ex. 2 (Optional);
- clay or plasticine for the Ending the Lesson activity.

## BEGINNING THE LESSON

(An activity to review the language from the previous lesson.)

Ask the students to present the drawings they made in the previous lesson.

## OUR WORLD

(Activities to familiarise students with aspects of British and American culture.)

**1** **Look at the pictures. Point and say: He's got ... . Then, match and say: He's got (big eyes).**

**Students' books open.** Say: *Open your books at page seventy-two.* Write the number 72 on the board and hold up your book. Point to the American flag and say: *USA.* If you have a map of the world, put it up on the board and show where the USA is. Ask the students if they know anything about the USA and have a class discussion in L1 (e.g. *famous people, cities, cartoon characters, etc.*). Explain to the students that in this section they will learn about popular cartoon characters. Tell the students to look at the American cartoon character. Point to it and say: *This is Mickey Mouse. Look! He's got big ears.* Repeat, this time asking the students to complete your sentences.

e.g. *Teacher: He's got ...  
Class: big ears. etc*

Point to the British flag and say: *UK.* Point to the picture of Wallace and Gromit and say: *This is Wallace and Gromit.* Point to Wallace and say: *Look! He's got a big nose.* Ask the students to describe the cartoon characters.

Next, focus the students' attention on the remaining cartoon characters and ask them to name the ones they know (*Pinocchio, Stitch, Lightning McQueen*). Point to Pinocchio's nose and elicit: *He's got a big nose.* Repeat with the rest of the cartoon characters.

Explain the task. Tell the students to match the parts of the face on the puzzle pieces to the cartoon characters. Then point to each cartoon character and have students describe them, e.g. (*pointing to Mickey*) *He's got big ears. etc*

## MY WORLD

(Activities for the students to explore and talk about their own culture in English.)

**2** **Draw your favourite cartoon character.**

Point to the picture of Cheburashka and say: *This is Cheburashka. Look! He has got big ears.* Ask students to tell you their favourite cartoon character. Then allow some time for the students to draw their favourite cartoon character. Alternatively, provide the students with a sheet of paper so they can draw their favourite cartoon character. Make sure you display their work somewhere in the classroom.

**3** **Play the Mirror Me game.**

Tell the students they are going to play a game. Ask the students, in pairs, to stand facing each other. One student is the leader and mimes an action, e.g. *brushing his/her teeth*, and his/her partner has to follow as accurately as possible, as if looking in the mirror. The rest of the class names the action.

## ENDING THE LESSON

(An activity to consolidate the language of the lesson.)

Tell the students that they are going to make a face of an animal or monster using plasticine or clay. Then they report back to the class, e.g. (*a monster's face*) *Look! Three eyes, two noses, etc.*

### Lesson 7 – Storyland

#### Objectives

To listen to a Russian story in English. To develop listening and speaking skills.

#### Language

In this lesson the students will learn to **understand**:

- *Can they pull the turnip out?*

In this lesson the students will learn to **use**:

- *pull, turnip*

#### Extra Materials

- None.

## BEGINNING THE LESSON

(An activity to revise the story.)

Ask the students if they remember what the previous episode of the story was about. If not, ask them to go to the respective page (60) and look at the picture.

# Module 5 – My Face

## PRESENTATION & PRACTICE

(Activities to present the tale of 'The Giant Turnip'.)

### ★ Listen to the story. (TRACK 46)

**Students' books open.** Say: *Open your books at page seventy-four.* Write the number 74 on the board and hold up your book. Direct the students' attention to the picture. Point to the characters and elicit their names. Point to the turnip and the characters and ask: *Can they pull the turnip out? Let's see!* Play the recording for the students to listen to the story. Play the recording again. The students listen and point to the characters as they are mentioned. Play the CD a third time with pauses. The students listen and repeat, chorally and/or individually.

### TAPESCRIPT

*"Please help us pull out the turnip!" Little Anna says to the dog. "Alright, I'm coming," says the dog. So, the dog holds Little Anna. Little Anna holds the old woman. The old woman holds the old man. The old man holds the turnip. They pull and pull. But they can't pull the turnip out! "We need help," says the dog. So he calls the cat.*

## ENDING THE LESSON

(An activity to consolidate the language of the lesson.)

Narrate the story. The students mime it.

### Lesson 8 – Checkpoint

#### Objectives

To consolidate the language of the module.

### 1 ★ What's missing? Draw. Then say.

Elicit the parts of the face. Explain the activity. The students draw the missing parts of the face and name them. Check the students' answers.

1 ears      2 mouth      3 eyes

### 2 ★ Listen and circle. (TRACK 47)

Explain the activity. Play the recording, twice if necessary. The students listen and circle the pictures. Check the students' answers.

**Items to be circled:** 1, 3, 4

### TAPESCRIPT

*Wash your hands.*

*Comb your hair.*

*Brush your teeth.*

**Note:** The students are now ready to do Module Test 5.

## Lesson 1

### Objectives

To present and practise the names of food items.

### Language

In this lesson the students will learn to **understand**:

- *What's this?*

In this lesson the students will learn to **use**:

- *Food: bananas, eggs, milk, sandwiches, biscuits, cheese.*
- *I like (biscuits). Give me some, please.*
- *Look! (Bananas, eggs and sandwiches)!*

### Extra Materials

- Flashcards (34-43) for the *Beginning the Lesson* activity;
- the *My Food* poster for *Presentation & Practice*;
- photocopies of the lunchbox and food items templates (pp. 111 - 113) for each student for Ex. 4 (*Craftwork*);
- flashcards (44-49) for the *Ending the Lesson* activity.

## BEGINNING THE LESSON

(An activity to revise the language from the previous module.)



### FLASHCARDS (34-43)

Display the flashcards on your desk. Ask a pair of students to come to the front. Give them some Blu-Tack and ask them to attach the cards on the board in the order you call them out. Ask the rest of the class for verification. Repeat the procedure with more pairs.

## PRESENTATION & PRACTICE

(Activities to present and practise the vocabulary of the lesson.)



### POSTER

### ★ Listen, point to the food items and say. (TRACK 48)

**Students' books closed.** Put up the *My Food* poster on the board. Point to the food items (*bananas, eggs, milk, sandwiches, biscuits, cheese*), one at a time, and present them. The students repeat after you. Point to the different items in random order. Individual students name the items.

**Students' books open.** Say: *Open your books at page seventy-six.* Write the number 76 on the board and hold up your book. Play the recording. The students listen, point and repeat.

### TAPESCRIPT

*Bananas, eggs, milk, sandwiches, biscuits, cheese.*



### 1 Listen and circle the food items you hear in the song. Then, point and say: *I like bananas, ...* (TRACK 49)

Elicit the names of the food items by pointing and asking: *What's this?* Point to the bananas and say: *I like bananas. Give me some, please.* The students repeat after you. Repeat the procedure with the rest of the food items. Play the recording. The students listen and circle the items they hear (*bananas, biscuits, sandwiches*). Then point to a food item, e.g. *biscuits*, rub your stomach and say: *I like (biscuits).* Ask students to make similar sentences about the food items on the table.

**Items to be circled:** bananas, biscuits, sandwiches

### TAPESCRIPT

*I like bananas,  
Bananas, bananas.  
I like bananas,  
Give me some, please.*

*I like biscuits,  
Biscuits, biscuits.  
I like biscuits,  
Give me some, please.*

*I like sandwiches,  
Sandwiches, sandwiches.  
I like sandwiches,  
Give me some, please.*



### 2 Listen and sing. (TRACK 50)

Play the recording. The students listen and sing along.

### Extension

Divide the class into three groups and assign a stanza from the song. The students sing along every time their stanza is heard.



### 3 Point to the pictures and name the food items. Then, draw the two missing food items in the correct order.

Tell the students to look at the pictures of the food items in their books. Elicit their names. Explain the activity. The students draw the missing food items in the correct order.

# Module 6 – My Food

**First sequence:** sandwich, biscuit

**Second sequence:** cheese, cheese

**Third sequence:** egg, milk

- 4** Colour and cut to make the lunchbox. Then, colour the food items. In pairs, ask for the food you like and put it in your lunchbox. Say: *I like (sandwiches). Give me some, please.*

### Before going into class

Photocopy the lunchbox and the food items templates, one per student.

Tell the students that they are going to make a lunchbox. Show them your model. Guide them through the cutting and colouring of their lunchboxes. Then ask them to cut out, colour the food items and spread them in front of them.

Upon completion, the students work in pairs. Students take turns saying which food items they like. Their partner hands them the food items to be put in their lunchboxes.

*e.g. Student 1: I like bananas. Give me some, please.*

*Student 2: (hands over the bananas for Student 1 to put in his/her lunchbox). etc*

As an extension, the students can present the food items in their lunchboxes, *e.g. Look! Bananas, eggs and sandwiches! etc.*

## ENDING THE LESSON

*(An activity to consolidate the language of the lesson.)*



### FLASHCARDS (44-49)

Show the food flashcards: *bananas, eggs, milk, sandwiches, biscuits, cheese*. Elicit the words. Put up the flashcards with the back showing on the board. Above them write the numbers 1 to 6 in sequence. Ask a student to choose a number and guess what the flashcard is, *e.g. 2 – eggs*. Turn the flashcard over. If it is correct leave it, if not, turn it over again and repeat the procedure with another student.

### WORKBOOK (Optional)

If you wish, you can do Exs 1 and 2 from the *Workbook* during this lesson or the next one.

## Lesson 2

### Objectives

To present and practise the names of food/drink items. To explore other subject areas: Health and Safety.

### Language

In this lesson the students will learn to **understand**:

- *What is your favourite food?*
- *Is it (eggs)?*
- *(Six) students like (bananas).*

In this lesson the students will learn to **use**:

- Food/drink: *tea, pizza, apples, popcorn, ice cream, cola.*
- *My turn!*
- *I like ... . Yummy!*
- *I don't like ... . Yuk!*
- *Picnics are yummy!*
- *Come on, everyone!*

### Extra Materials

- Flashcards (44-49) for the *Beginning the Lesson* activity;
- flashcards (50-55) for *Presentation & Practice*;
- A4 sheets of paper for each student for Ex. 3 (Extension).

## BEGINNING THE LESSON

*(An activity to review the language from the previous lesson.)*



### FLASHCARDS (44-49)

Do a class survey. Put up the flashcards of the food items (*bananas, eggs, milk, sandwiches, biscuits, cheese*) on the board. Ask the students: *What is your favourite food?* Point to the flashcards, one at a time, and ask: *Is it eggs?* The children raise their hands when you name their favourite food. Count the hands and write the number under the corresponding flashcard. When you finish the survey, say: *(Six) students like bananas. etc*

## PRESENTATION & PRACTICE

*(Activities to present and practise the vocabulary of the lesson.)*



**★ Listen, point to the food items and say. (TRACK 51)**



**FLASHCARDS (50-55)**

**Students' books closed.** Put up the food flashcards on the board. Point to the food items (*tea, pizza, apples, popcorn, ice cream, cola*), one at a time, and present them. The students repeat after you.

Hand out the flashcards to various students. Ask the students to come to the board, one at a time, show their flashcard and say the corresponding word. Ask the rest of the class for verification.

**Students' books open.** Say: *Open your books at page seventy-eight.* Write the number 78 on the board and hold up your book. Play the recording. The students listen, point and repeat.

**TAPESCRIPT**

*Tea, pizza, apples, popcorn, ice cream, cola.*

**★ 1 Play the *It's good/bad for your teeth* game!**

Tell the students that they are going to play a board game. Point to the picture and elicit the names of the items. Ask the students, in L1 if necessary, which food/drink items are bad for our teeth and should be avoided and which ones are good.

Explain the rules. The students play in pairs and each player needs a counter (*any small object will do*). They place their counters on *Start* and throw the dice, saying the number that comes up. The student with the highest number begins the game by saying *My turn!* and moves forward the number of spaces indicated on the dice. If a student lands on a 'bad' food type he/she colours the corresponding tooth black. The game continues until both students reach the end.

When the students finish playing, have them show their drawings to the class.

**★ 2 Listen and draw. Then, say: *I like (ice cream). Yummy!, I don't like ... Yuk!* (TRACK 52)**

Point to the pictures of the food items and elicit their names. Point to the ice cream and say: *I like ice cream. Yummy!* The students repeat after you. Point to the picture of the *apples* and say: *I don't like apples. Yuk!* The students repeat after you. Explain the activity. Play the recording. The students listen and draw a smiley face or a sad face. Then the students talk about the pictures by saying: *I like... . Yummy! or I don't like ... . Yuk!*

**TAPESCRIPT**

- 1 *I like ice cream. Yummy!*
- 2 *I don't like apples. Yuk!*
- 3 *I don't like popcorn. Yuk!*
- 4 *I like pizza. Yummy!*

**★ 3 Listen and sing. (TRACK 53)**

Point to the picture and say: *It's a picnic.* Then say: *Picnics are yummy!* The students repeat after you. Elicit the food items shown. Then beckon and say: *Come on, everyone!* The students repeat after you.

Play the recording. The students listen and point to the food items. Play the recording again. The students listen and sing along.

**TAPESCRIPT**

*Picnics are yummy,  
Picnics are fun!  
Popcorn and pizza,  
Come on, everyone!*

*Picnics are yummy,  
Picnics are fun!  
Ice cream and cola,  
Come on, everyone!*

**Extension**

Provide each student with a sheet of paper. Tell the class they are going to have a picnic with their friends. Ask them to draw the food items they will take with them. Ask individual students to present their drawings to the class. Make a class display.

*e.g. Student 1: Picnics are yummy. Look! Ice cream and cola. Come on, everyone!*

**ENDING THE LESSON**

*(An activity to consolidate the language of the lesson.)*



**FLASHCARDS (44-55)**

Put up the flashcards with the food items on the board. Allow the students some time to look at them. Then ask the students to close their eyes. Remove one of the flashcards. Ask the students to open their eyes and tell you which food item is missing. Repeat the activity with the other food items.

**WORKBOOK (Optional)**

If you wish, you can do Exs 3 and 4 from the *Workbook* during this lesson or the next one.

# Module 6 – My Food

## Lesson 3

### Objectives

To listen to a story about the characters having a picnic. To develop listening comprehension skills through a dialogue.

### Language

In this lesson the students will learn to **understand**:

- *Who's this?*
- *Let's have a picnic!*

In this lesson the students will learn to **use**:

- *What's your favourite food?*
- *(Pizza), yum!*

### Extra Materials

- Flashcards (44-55) for the *Beginning the Lesson* activity;
- the *My Food* poster for *Presentation & Practice*.

## BEGINNING THE LESSON

(An activity to review the language from the previous lesson.)



### FLASHCARDS (44-55)

Put up the flashcards on the board. Ask a pair to come to the front. The students ask and answer questions about their favourite food items using the flashcards. Demonstrate this yourself first.

e.g. Student 1: *What's your favourite food?*

Student 2: *(pointing to the pizza) Pizza, yum!  
What's your favourite food?*

Student 1: *(pointing to the ice cream) Ice cream,  
yum! etc*

## PRESENTATION & PRACTICE

(Activities to present the story and develop students' listening skills.)



### 1 Listen to the story and point to the pictures. (TRACK 54)



### POSTER

**Students' books closed.** Use the *My Food* poster to present the story. Explain to the students, in L1 if necessary, that Woody and his friends are having a picnic. Point to Erlina in the first picture and ask: *Who's this?* Elicit: *Erlina*. Say as you point to the basket: *Let's*

*have a picnic!* The students repeat after you. Point to the food items in the second picture and say: *Look! Sandwiches, biscuits, tea!* The students repeat after you. Repeat with the rest of the pictures.

**Students' books open.** Say: *Open your books at page eighty.* Write the number 80 on the board and hold up your book. Ask students to identify the characters and the food items they know.

e.g. Student: *(pointing to Woody in Frame 1)  
(This is) Woody! etc*

Play the recording and ask the students to point to each picture in their book in turn. Show them what to do by holding up your book and pointing. Play the recording again. The students listen and repeat, chorally and/or individually.

Point to the first picture on the poster. Ask the students to complete your sentences.

e.g. Teacher: *Let's have a ...*  
Class: *picnic! etc*

### Extension

Ask for a volunteer to come and point to the first picture on the poster. Encourage him/her to say the dialogue. Ask the rest of the class for verification. Repeat with different students for the rest of the story.

### TAPESCRIPT

#### Frame 1

Erlina: *Let's have a picnic!*

#### Frame 2

Alvin: *Look! Sandwiches, biscuits, tea!*

#### Frame 3

Woody: *I like tea. Yummy!*

#### Frame 4

Woody: *Tea, Frosty?*

Frosty: *What's tea?*

#### Frame 5

Frosty: *I don't like tea!*

#### Frame 6

Woody: *Erlina! Help!*

#### Frame 7

Frosty: *Yummy! I like ice cream!*

#### Frame 8

Woody: *Picnics are fun!*

Read the question at the bottom of page 81. Ask the students to draw a happy face or a sad face depending on whether they like the story or not. Ask them to tell you, in L1 if necessary, what they like most.

## ENDING THE LESSON

(An activity to consolidate the language of the lesson.)

Draw a tree on the board. Tell the students that this is a magic tree and any kind of food or drink can 'grow' on it. Ask individual students to name a food/drink item. Draw a simple sketch of it on the tree. Continue until all students have had a turn and the tree is full.

### Lesson 4

#### Objectives

To talk about food items and say where we get them from.

#### Language

In this lesson the students will learn to **understand**:

- *We get apples from a tree.*

In this lesson the students will learn to **use**:

- *apples, milk, eggs, cheese, bananas, cow, tree, chicken*

#### Extra Materials

- A4 sheets of paper for each student for the *Ending the Lesson* activity.

## BEGINNING THE LESSON

(An activity to revise the dialogue.)

Play the dialogue from the previous lesson (Track 54). The students listen and follow in their books.

## PRESENTATION & PRACTICE

(Activities to talk about food items and where we get them from.)

### 1 Trace the food items. Then, draw lines.

**Students' books closed.** Draw a simple sketch of two apples on the board. Ask students in L1 to tell you where apples come from. Elicit the answer. Then point to them and say: *We get apples from a tree.* The students repeat after you. Draw simple sketches of a *chicken* and a *cow* and present the words.

**Students' books open.** Say: *Open your books at page eighty-two.* Write the number 82 on the board and hold up your book. Point to the outline of the items and elicit their names. Ask the students to trace them. Then ask the students to draw lines to match. Check the students' answers. Finally, the students say where we get these food items from.

We get apples from a tree.  
We get bananas from a tree.  
We get cheese from a cow.  
We get milk from a cow.  
We get eggs from a chicken.

As an extension, students can name other food items and say where we get them from.

### 2 Spot the differences.

Explain the activity. Allow the students some time to find and circle the differences. Then the students point to and say the differences.

#### (Suggested answers)

**Student 1:** (*pointing to the eggs in picture A*) Three eggs.

(*pointing to the eggs in picture B*) Two eggs.

**Student 2:** (*pointing to the apples in picture A*) (Three) apples under the table.

(*pointing to the apples in picture B*) (Three) apples in the cupboard.

**Student 3:** (*pointing to the chicken in picture A*) A (One) chicken on the table.

(*pointing to the chicken in picture B*) A (One) chicken under the table.

**Student 4:** (*pointing to the pizza in picture A*) A pizza in the cupboard.

(*pointing to the pizza in picture b*) A pizza under the table.

## ENDING THE LESSON

(An activity to consolidate the language of the lesson.)

Provide each student with a sheet of paper. As an extension, the students can draw a farm with animals, trees and plants. They present, in L1 if necessary, what we get from them. Display their work somewhere in the classroom.

# Module 6 – My Food

## Lesson 5

### Objectives

To consolidate the language learnt in the module.  
To draw a picture of one's favourite food.

### Language

In this lesson the students will learn to **understand**:

- *Does Frosty like (ice cream)?*

In this lesson the students will learn to **use**:

- *Do you like (ice cream), Frosty?*
- *Yes. Yummy!*
- *No. Yuk!*
- *I like (pizza)! Yummy!*

### Extra Materials

- The *My Food* poster for the *Beginning the Lesson* activity;
- A4 sheets of paper for each student for Ex. 3;
- a round piece of paper for each student for the *Ending the Lesson* activity.

## BEGINNING THE LESSON

(An activity to revise the language of the previous lesson.)



### POSTER

Put up the *My Food* poster. Ask a student to come to the board. Name a food item. He/She points to it and names it. Ask the rest of the class for verification. Repeat with as many students as you think is necessary.

## PRACTICE

(Activities to consolidate food items.)



**1 Find the food items. Use the code and colour them.**

Say: *Open your books at page eighty-four.* Write the number 84 on the board and hold up your book. Refer the students to the picture and explain the activity. Allow the students some time to find and colour the food items. Check their answers.



**2 Look and talk with your friend: *Do you like (milk), Frosty? Yes. Yummy/No. Yuk!***

Go through the pictures and elicit the names of the items. Explain the activity. Point to the child holding the Alvin puppet and say: *Do you like ice cream, Frosty?* Then point to the child holding the Frosty puppet and say: *Yes. Yummy!* Elicit which food/drink items Frosty

likes/doesn't like. Say: *Does Frosty like milk?* Elicit the correct response. Then the students use the character puppets and act out the short exchanges. Check around the classroom, providing any necessary help.

### (Suggested answers)

**A:** *Do you like milk, Frosty?*

**B:** *Yes. Yummy!*

**A:** *Do you like apples, Frosty?*

**B:** *Yes. Yummy!*

**A:** *Do you like ice cream, Frosty?*

**B:** *Yes. Yummy!*

**A:** *Do you like biscuits, Frosty?*

**B:** *Yes. Yummy!*

**A:** *Do you like tea, Frosty?*

**B:** *No. Yuk!*

**A:** *Do you like eggs, Frosty?*

**B:** *No. Yuk!*

**A:** *Do you like pizza, Frosty?*

**B:** *No. Yuk!*

**A:** *Do you like bananas, Frosty?*

**B:** *No. Yuk!*



**3 Portfolio: Draw a picture of your favourite food. Present it to the class. Say: *I like (pizza). Yummy!***

(An activity to develop fine motor skills and consolidate the language of the module.)

Point to the picture of the *pizza*. Then say: *Pizza is my favourite food!* Provide each student with a sheet of paper. Ask the students to draw a picture of their favourite food and present it to the class by saying, e.g. *I like (pizza). Yummy!* Make sure you display their work somewhere in the classroom. Then help them file their drawings in their *Junior Language Portfolios*.

## ENDING THE LESSON

(An activity to consolidate the language of the lesson.)

### Before going into class

Bring in round pieces of paper, one for each student.

Tell the students they are going to make a funny pizza. Give each student a round piece of paper. Tell them to make their own pizza by drawing the food items they know in English. When they finish, they report back to the class.

e.g. Teacher: Chris, what's on your pizza?  
 Chris: Cheese and ice cream!  
 Class: Yummy!

## WORKBOOK (Optional)

If you wish, you can do Exs 5 and 6 from the *Workbook* during this lesson or the next one.

## Lesson 6 – Our World/My World

### Objectives

To familiarise students with British, Chinese, Turkish and Russian culture. To talk about tea in the UK/China/Turkey/Russia.

### Language

In this lesson the students will learn to **understand**:

- UK, China, Turkey, Russia
- Do you drink tea?
- Biscuits and milk, change places!

In this lesson the students will learn to **use**:

- I like (apples).

### Extra Materials

- A map of the world for Ex. 1 (Optional);
- slips of paper with food/drink items drawn on them for the *Ending the Lesson* activity.

## BEGINNING THE LESSON

(An activity to review the language from the previous lesson.)

Ask the students to present the drawings they made in the previous lesson.

## OUR WORLD

(Activities to familiarise students with aspects of British, Chinese and Turkish culture.)

- 1 **Look at the pictures and talk about tea. Circle the things you can eat with tea in the UK.**

**Students' books open.** Say: *Open your books at page eighty-six.* Write the number 86 on the board and hold up your book. Point to the British flag and say: *UK.* Explain to the students that in this section they will talk about *tea time* in Britain. Point to the picture of the *tea* and tell students that drinking afternoon tea is very popular in Britain.

Next, point to the Chinese and Turkish flags, one at a time. If you have a map of the world, put it up on the board and show where *China* and *Turkey* are. Ask the students if they know anything about China/Turkey and have a class discussion in L1 (e.g. *famous people, cities etc.*).

Next, focus the students' attention on the food items and tell them to circle the ones that are usually eaten with tea in the UK (*biscuits, sandwiches*).

## MY WORLD

(Activities for the students to explore and talk about their own culture in English.)

- 2 **Do you drink tea in your country? What do you eat with your tea? Draw or stick a picture.**

Ask students to tell you if they drink tea in their country and if it is popular. Then, they draw a picture connected with tea (e.g. teapot and tea cups, popular brands, etc).

- 3 **Play the *Add to it* game.**

Ask the students to look at the pictures. Point to the picture of the boy and say: *I like apples.* The students repeat after you. Then point to the picture of the girl and say: *I like apples and milk.* The students repeat after you.

Tell the class they are going to play a game. Demonstrate this yourself first. Say: *I like bananas.* Choose a student to continue by repeating what you said and then saying what he/she likes, e.g. *I like bananas and apples.* Continue the game until everyone has had a turn.

## ENDING THE LESSON

(An activity to consolidate the language of the lesson.)

### Before going into class

Prepare slips of paper with simple drawings of food and drink items.

Tell the students to form a circle with their chairs. Hand out slips of paper with food/drink items drawn on them. Tell the students they must not tell anyone what food/drink item they have. Explain the activity. You stand in the centre and call out a food and drink item, e.g. *Biscuits and milk, change places!* The students with the respective items stand up and change places.



# Module 6 – My Food

## Lesson 7 – Storyland

### Objectives

To listen to a Russian story in English. To develop listening and speaking skills.

### Language

In this lesson the students will learn to **understand**:

- *Can they pull the turnip out?*

In this lesson the students will learn to **use**:

- *pull, turnip*

### Extra Materials

- None.

## BEGINNING THE LESSON

*(An activity to review the story.)*

Ask the students if they remember what the previous episode of the story was about. If not, ask them to go to the respective page (74) and look at the picture.

## PRESENTATION & PRACTICE

*(Activities to present the tale of 'The Giant Turnip'.)*



### Listen to the story. (TRACK 55)

**Students' books open.** Say: *Open your books at page eighty-eight.* Write the number 88 on the board and hold up your book. Direct the students' attention to the picture. Point to the characters and elicit their names. Point to the turnip and the characters and ask: *Can they pull the turnip out? Let's see!* Play the recording for the students to listen to the story. Play the recording again. The students listen and point to the characters as they are mentioned. Play the CD a third time with pauses. The students listen and repeat, chorally and/or individually.

### TAPESCRIPT

*"Please help us pull out the turnip!" the dog says to the cat. "Alright, I'm coming," says the cat. So, the cat holds the dog. The dog holds Little Anna. Little Anna holds the old woman. The old woman holds the old man. The old man holds the turnip. They pull and pull. But they can't pull the turnip out. "We need help," says the cat. So she calls the mouse.*

## ENDING THE LESSON

*(An activity to consolidate the language of the lesson.)*

Narrate the story. The students mime it.

## Lesson 8 – Checkpoint

### Objectives

To consolidate the language of the module.



### 1 Listen and circle. (TRACK 56)

Revise the food items. Explain the activity. Play the recording, twice if necessary. The students listen and circle the food items heard. Check the students' answers.

**Items to be circled:** sandwich, cheese, eggs, biscuits, pizza, bananas, tea

### TAPESCRIPT

*Sandwich, cheese, eggs, biscuits, pizza, bananas, tea.*



### 2 Draw lines. Say.

Point to and read the words, *yummy* and *yuk*. Hold up your book point to milk and draw an imaginary line to the *yummy* word. Say: *I like milk. Yummy!* Point to cola, draw an imaginary line to the *yuk* word and say: *I don't like cola. Yuk!* Explain the activity. The students draw lines depending on whether they like the food items or not. Then, students report back to the class.

### (Suggested answers)

**Student 1:** *I like pizza. Yummy! I don't like tea. Yuk!*

**Student 2:** *I like sandwiches. Yummy! I don't like milk. Yuk!*

**Student 3:** *I like cheese. Yummy! I don't like popcorn. Yuk!*

**Student 4:** *I like biscuits. Yummy! I don't like bananas. Yuk!*

**Student 5:** *I like cola. Yummy! I don't like eggs. Yuk!*

**Student 6:** *I like ice cream. Yummy! I don't like apples. Yuk!*

**Note:** The students are now ready to do Module Test 6.



## Lesson 1

### Objectives

To present and practise the names of animals and identify the sounds they make.

### Language

In this lesson the students will learn to **understand**:

- *What's this?*
- *How many (cows)?*

In this lesson the students will learn to **use**:

- Animals: *cat, cow, hen, dog, sheep, horse.*
- *The (sheep) goes (baa)!*
- *Look! Two (yellow cows)!*
- *This is a (cat). The (cat) goes (miaow)!*

### Extra Materials

- Flashcards (44-55) for the *Beginning the Lesson* activity;
- the *My Animals* poster for *Presentation & Practice*;
- flashcards for the *Ending the Lesson* activity.

## BEGINNING THE LESSON

(An activity to review the vocabulary taught in Module 6.)



### FLASHCARDS (44-55)

Put up the flashcards on the board. Name a food/drink item at random. Ask students to come to the front, point to and name the food/drink item. Ask the rest of the class for verification.

## PRESENTATION & PRACTICE

(Activities to present and practise farm animals and the sounds they make.)



**Listen, point to the animals and say.**  
(TRACK 57)



### POSTER

**Students' books closed.** Put up the *My Animals* poster on the board. Point to the animals (*cat, cow, hen, dog, sheep, horse*), one at a time, and say the word. The students repeat after you. Point to the animals in random order. The students repeat after you.

Make an animal sound. Students identify the animal.

e.g. Teacher: *Moo!*  
Class: *Cow! etc*

**Students' books open.** Say: *Open your books at page ninety.* Write the number 90 on the board and hold up

your book. Play the recording. The students listen, point to the animals and repeat. Check their pronunciation and intonation.

### TAPESCRIPT

*Cat, cow, hen, dog, sheep, horse.*



**Listen and number the animals in the order you hear them. Then, sing and do. (TRACK 58)**

Hold up your book and point to the animals shown in the picture, one at a time, asking the students: *What's this?* and eliciting: *It's a ...*. Then point to the dog and say: *The dog on the farm goes woof, woof, woof all day!* The students repeat after you. Follow the same procedure with the rest of the animals.

Explain the activity to the students. Tell them to number the animals in the order they hear them (1-6), while listening to the song. Play the recording. The students listen and complete the activity. Play the recording again, encouraging the students to sing along.

dog (1)	cow (3)	sheep (5)
cat (2)	hen (4)	horse (6)

### TAPESCRIPT

*The dog on the farm  
Goes woof, woof, woof,  
Woof, woof, woof,  
Woof, woof, woof!  
The dog on the farm  
Goes woof, woof, woof,  
Woof, woof, woof all day!*

*Cat ... miaow  
Cow ... moo  
Hen ... cluck  
Sheep ... baa  
Horse ... neigh*



**Look and find the animals. Then, say: *The (dog) goes (woof)!***

Refer the students to the pictures, point to the animals and elicit the names. Ask the students to find the corresponding animals in the picture and say, e.g. *The sheep goes baa! etc.*



**Colour the picture.**

Refer the students to the picture, point to the animals and elicit the names. Point to the cows and ask: *How many cows?* Elicit the correct response: *Two.* Repeat the same procedure with the rest of the animals. Explain the activity. Ask the students to colour the animals. Allow them some time to complete the activity.

# Module 7 – My Animals

## ★ 4 Present the picture to the class. Say: *Look! (Two yellow cows!)*

Ask individual students to hold up their book for the rest of the students to see, and present their picture to the class. Demonstrate this yourself first.

e.g. *Student 1: Look! Two yellow cows! Three green horses! Three red dogs! Three blue cats! Four orange hens! One pink sheep! etc*

## ENDING THE LESSON

(An activity to consolidate the language of the lesson.)



### FLASHCARDS (56-61)

Show students one flashcard at a time. The class makes the corresponding animal sound. Demonstrate this yourself first.

e.g. *This is a cat. The cat goes miaow! etc*

### WORKBOOK (Optional)

If you wish, you can do Exs 1 and 2 from the *Workbook* during this lesson or the next one.

## Lesson 2

### Objectives

To present and practise actions and abilities. To explore other subject areas: PE & Drama.

### Language

In this lesson the students will learn to **understand**:

- *(Pips), (fly) like a (bat)!*
- *What can (you) do?*

In this lesson the students will learn to **use**:

- *Actions: jump, climb, swim, fly, run.*
- *I'm a (horse) and I can (jump).*
- *It's a (bat). It can (fly).*

### Extra Materials

- Flashcards (56-61) for the *Beginning the Lesson* activity;
- flashcards (62-66) for *Presentation & Practice*;
- photocopies of the animals templates (pp. 114 - 118) and drinking straws for each student for Ex. 3;
- flashcards (62-66) for the *Ending the Lesson* activity.

## BEGINNING THE LESSON

(An activity to review animals and animal sounds.)



### FLASHCARDS (56-61)

Place the animals flashcards in random places around the classroom. Next to each flashcard place/write a number from 1-6. Tell the students to walk around the classroom while you play the song from the previous lesson. When the music stops, the students should stand next to the nearest animal flashcard. Call out a number (1-6) and each group should name the animal and make the corresponding animal sound.

## PRESENTATION & PRACTICE

(Activities to present and practise actions.)



### Listen, point to the actions and say. (TRACK 59)



### FLASHCARDS (62-66)

**Students' books closed.** Put up the flashcards 62-66 on the board. Point to the actions (*jump, climb, swim, fly, run*), one at a time, and say the word. The students repeat after you. Point to the actions in random order. Ask individual students to name the actions.

**Students' books open.** Say: *Open your books at page ninety-two.* Write the number 92 on the board and hold up your book. Play the recording. The students listen, point and repeat.

### TAPESCRIPT

*Jump, climb, swim, fly, run.*



### 1 Play the *Pip, Squeak, Wilfred* game.

Ask the students to stand in a circle. Assign roles (*Pip, Squeak, Wilfred*) by going around and patting the students on their shoulders. Demonstrate the game. Say: *Pips, fly like a bat!* The students that belong in that group, mime flying. Repeat the procedure using the rest of the prompts (*jump like a horse, climb like a cat, swim like a duck, run like a mouse*), as many times as you think is necessary.



### 2 Point to each picture, mime the action and say: *I'm a (horse) and I can (jump).* Then, sing and do. (TRACK 60)

Say as you jump: *I'm a horse and I can jump.* The students repeat after you. Follow the same procedure

## Lesson 3

with the rest of the actions. Ask the students to point to each picture, mime and say the actions. Play the recording. The students listen and do the actions. Play the recording again. The students sing and do the actions.

### TAPESCRIPT

*I'm a horse and I can jump.*

*I'm a horse and I can jump.*

*I'm a horse and I can jump.*

*I can jump like this!*

*I'm a cat and I can climb ...*

*I'm a duck and I can swim ...*

*I'm a bat and I can fly ...*

*I'm a mouse and I can run ...*

**3** Use the template to make your animals. Then, say: *It's a (bat). It can (fly).*

### Before going into class

Photocopy the animals templates and give one photocopy to each student. The students cut the templates and stick them onto drinking straws.

Point to the picture of the boy holding the bat and say: *It's a bat. It can fly.* Hand out the photocopies. Show them your model and guide them through the cutting, colouring and sticking of their animals onto the straws. Invite individual students to hold up their animal and present it to class by saying what the animal is and what it can do.

e.g. Student 1: *It's a (bat). It can (fly).*

As an extension, you can play the song again and the students hold up the animal puppets every time the animals are mentioned.

## ENDING THE LESSON

(An activity to review actions.)



### FLASHCARDS (62-66)

Invite students, one by one, to the front of the classroom. Hand them an animal flashcard and ask them to mime the action. The rest of the class has to guess what it is. The first student to answer correctly takes the next turn.

### WORKBOOK (Optional)

If you wish, you can do Exs 3 and 4 from the *Workbook* during this lesson or the next one.

### Objectives

To listen to a story about some forest animals helping Woody and Frosty. To develop listening comprehension skills through a dialogue.

### Language

In this lesson the students will learn to **understand**:

- *Who's this?*
- *Let's play!*

In this lesson the students will learn to **use**:

- *Can you (swim)?*
- *No, but I can (jump)!*
- *Yes, I can!*
- *I can (fly)!*

### Extra Materials

- The *My Animals* poster for *Presentation & Practice*.

## BEGINNING THE LESSON

(An activity to review actions.)

Play the song from the previous lesson (Track 60). The students listen and do the actions.

## PRESENTATION & PRACTICE

(Activities to present the story and develop students' listening skills.)

**1** Listen to the story and point to the pictures. (TRACK 61)



### POSTER

**Students' books closed.** Use the *My Animals* poster to present the story. Explain to the students, in L1 if necessary, that Woody and Frosty's ball is in the lake and they want their friends to help them get it back. Point to Woody in the first picture and ask: *Who's this?* Elicit: *Woody.* Say, as you point to the ball: *Let's play!* The students repeat after you. Point to the ball in the lake in the second picture and say: *Oh, no! Can you swim, Woody?* The students repeat after you. Repeat with the rest of the pictures.

**Students' books open.** Say: *Open your books at page ninety-four.* Write the number 94 on the board and hold up your book. Ask students to identify the characters and the animals they know.

e.g. Student 1: (pointing to Woody in Frame 1) *(This is) Woody! etc*

# Module 7 – My Animals

Play the recording and ask the students to point to each picture in their book in turn. Show them what to do by holding up your book and pointing. Play the recording again. The students listen and repeat, chorally and/or individually.

Point to the first picture on the poster. Ask the students to complete your sentences.

e.g. *Teacher: Let's ...*  
*Class: play! etc*

## Extension

Ask for a volunteer to come and point to the first picture on the poster. Encourage him/her to say the dialogue. Ask the rest of the class for verification. Repeat with different students for the rest of the story.

## TAPESCRIPT

### Frame 1

Frosty: *Let's play!*

### Frame 2

Frosty: *Oh, no! Can you swim, Woody?*  
Woody: *No!*

### Frame 3

Woody: *Can you swim, Ronny?*  
Ronny: *No, but I can jump!*

### Frame 4

Woody: *Can you swim, Bertie?*  
Bertie: *No, but I can fly!*

### Frame 5

Frosty: *Can you swim, Carla?*  
Carla: *No, but I can climb!*

### Frame 6

Frosty: *Can you swim, Daisy?*  
Daisy: *Yes, I can!*

### Frame 7

Woody: *Thank you, Daisy!*

### Frame 8

Woody: *Let's all play!*

Read the question at the bottom of page 95. Ask the students to draw a happy face or a sad face, depending on whether they like the story or not. Ask them to tell you, in L1 if necessary, what they like most.

## ENDING THE LESSON

(An activity to consolidate the language of the lesson.)

Mime an action (*jump, climb, run, swim, fly*). The students call out the word. Change the actions quickly

to make the activity fun for the students. Invite a student to come to the front of the classroom and take your role.

## Lesson 4

### Objectives

To talk about animals and what they can do.

### Language

In this lesson the students will learn to **understand**:

- *What can a (lion) do?*
- *Can you (jump)?*

In this lesson the students will learn to **use**:

- *It can (run).*
- *Yes, I can./No, I can't.*

### Extra Materials

- Pictures of animals (*a lion, a polar bear, a hippo, a parrot, a flamingo and a penguin*) for *Presentation & Practice*.

## BEGINNING THE LESSON

(An activity to review the dialogue from the previous lesson.)

Play the dialogue from the previous lesson (Track 61). The students listen and follow in their books.

## PRESENTATION & PRACTICE

(Activities to talk about animals and what they can do.)



**1 Look at the animals. What can they do? Colour. Then, point and say: *It can ...***

### Before going into class

Have the pictures of the animals ready to use.

**Students' books closed.** Put up the animal pictures (*lion, polar bear, hippo, parrot, flamingo, penguin*) on the board. Elicit what the animals can do.

**Students' books open.** Say: *Open your books at page ninety-six.* Write the number 96 on the board and hold up your book. Point to the actions and elicit the words and the colours. Explain the activity. Ask the students: *What can a lion do?* and elicit responses (*It can run.*). Explain to the students that they colour in a petal using the corresponding colour for *run* (*i.e. red*). Repeat with the rest of the animals in the pictures, allowing the

students time to colour the corresponding petals according to the colour of the actions. Then, students point to the animals in turn and say: *It can (run) ... etc.*

**lion:** run – climb – swim

**(polar) bear:** run – climb – swim

**parrot:** run – climb – fly

**hippo:** run – swim

**flamingo:** run – fly – swim

**penguin:** run – swim

## ★ 2 Look and spot the mistakes. Then, say: A (lion) can't (fly).

Explain the activity. Point to and elicit the names of the animals. Point to the animal and ask: *Can a lion fly?* Elicit the right response (*no*). Answer: *A lion can't fly.* Allow the students some time to find and circle the mistakes. Then, students say what the animals can't do.

**Items to be circled:** lion, bear, parrot, hippo, penguin

A lion can't fly.

A bear can't fly.

A parrot can't swim.

A hippo can't climb.

A penguin can't climb.

## ENDING THE LESSON

(An activity to consolidate the language of the lesson.)

Ask individual students to come to the front of the classroom. Say an action, e.g. *climb*. The students mime climbing. Repeat with other actions (e.g. *run, fly, swim*). Repeat the activity with as many students as you think is necessary.

### Lesson 5

#### Objectives

- To consolidate the language learnt in the module.
- To draw a picture of a farm.

#### Language

In this lesson the students will learn to **understand**:

- How many animals are there on the farm?
- Willow says, *jump!*

In this lesson the students will learn to **use**:

- Yes, I can./No, I can't.*
- This is my farm. Look! A (horse), ...*

#### Extra Materials

- Flashcards (56-61) for the *Beginning the Lesson* activity;
- A4 sheets of paper for each student for Ex. 3.

## BEGINNING THE LESSON

(An activity to review animals.)



### FLASHCARDS (56-61)

Ask a student to come to the front of the classroom. Show him/her an animal flashcard. The student names the animal and one thing it can do. Ask the rest of the class for verification. Repeat with as many students as you think is necessary.

## PRACTICE

(Activities to consolidate animals and abilities.)

### ★ 1 Find the animals. Draw lines.

Say: *Open your books at page ninety-eight.* Write the number 98 on the board and hold up your book. Refer the students to the picture and explain the activity. Allow the students some time to find the animals and draw lines. Check their answers.

### ★ 2 Look and circle. Then, talk with your friend: Can you (jump)? Yes/No.

Refer the students to the pictures and elicit the actions. Explain the activity. The students circle the *happy face* or the *sad face* according to what they can/cannot do. Then ask the students, in pairs, to ask and answer these questions. Demonstrate this yourself first.

e.g. Student 1: *Can you jump?*

Student 2: *Yes, I can./No, I can't. etc*

### ★ 3 Portfolio: Draw a picture of your farm. Present it to the class. Say: *This is my farm. Look! A (duck), ...*

Point to the picture and ask: *What's this?* Elicit: *It's a farm.* Ask: *How many animals are there in the farm?* Elicit: *Four.* Then say: *This is my farm. Look! A horse, a sheep and two cows!* Provide each student with a sheet of paper. Ask the students to draw their own farm and present it to the class. Make sure you display their work somewhere in the classroom. Then help them file their drawings in their *Junior Language Portfolios*.

## ENDING THE LESSON

(An activity to consolidate the language of the lesson.)

Play *Willow says*. Explain to the students that they should do the actions only if they are preceded by the phrase



# Module 7 – My Animals

Willow says. Demonstrate this yourself first.

e.g. Teacher: Willow says, jump!

Class: (students jump)

Teacher: Climb!

Class: (students remain still) etc

## WORKBOOK (Optional)

If you wish, you can do Exs 5-6 from the *Workbook* during this lesson or the next one.

### Lesson 6 – Our World/My World

#### Objectives

To familiarise students with Australian, Peruvian, Chinese and Russian culture. To talk about popular animals in Australia/Peru/China/Russia.

#### Language

In this lesson the students will learn to **understand**:

- Australia, Peru, China, Russia
- koala, llama, panda

In this lesson the students will learn to **use**:

- A (green) (koala) ...

#### Extra Materials

- A map of the world for Ex. 1 (Optional);
- flashcards (56-61) for Ex. 4;
- flashcards (62-66) for the *Ending the Lesson* activity.

## BEGINNING THE LESSON

(An activity to review the language from the previous lesson.)

Ask the students to present the drawings they made in the previous lesson.

## OUR WORLD

(Activities to familiarise students with aspects of Australian, Peruvian and Chinese culture.)

- 1 **Look at the pictures and talk about the animals. Colour the animals. Then, point and say: A green koala, ... .**

**Students' books closed.** Ask the students, in L1 if necessary, what the most popular animals are in their country. Explain to them that today they are going to learn about popular animals in Australia, Peru, China and Russia.

**Students' books open.** Say: *Open your books at page a hundred.* Write the number 100 on the board and hold up your book. Point to the Australian flag and say: *Australia.* If you have a map of the world, put it up on the board and show where Australia is. Repeat the same procedure with the flags of *Peru* and *China.* Point to the pictures and ask the students to identify the animals. Point to the first picture and say: *koala.* The students repeat, chorally and individually. Continue with the other animals: *llama, panda.* The students repeat, chorally and individually. Ask the students if they have heard of these animals and what they know about them.

Point to the groups of pictures below. Ask the students to look carefully at each group of pictures and colour the remaining ones according to the sequence the other pictures form. Then students point to the animals and say: *A green koala, a yellow koala, ... .*

**The students colour:** koalas – green, yellow; llamas – blue, blue; pandas – orange, green

## MY WORLD

(Activities for the students to explore and talk about their own culture in English.)

- 2 **Circle the animals that live in Russia.**

Ask students to name, in L1 if necessary, some wild animals that live in Russia (e.g. wolf, Siberian tiger, etc). Point to the pictures and name the animals. Explain the activity. Allow the students some time to complete the activity. Check the students' answers.

**Animals to be circled:** Siberian tiger, wolf, bear

- 3 **Draw and colour your favourite animal. Then, say: This is ... .**

Explain the activity. The students draw and present their favourite animal. Alternatively, the students can draw their favourite animal on a piece of paper. If you wish, you can write the English name on the picture.

- 4 **Play the *Animals* game.**



### FLASHCARDS (56-61)

Put the flashcards face down on your desk. Ask a student to come to the front of the classroom and pick a flashcard. The student says an action that this animal can do. The rest of the class tries to guess the animal. Whoever guesses correctly, comes to the front of the classroom and the game continues.



e.g. Student 1: (picks the cat flashcard) I can climb.  
Student 2: You're a horse.  
Student 1: No!  
Student 3: You're a cat!  
Student 1: Yes. etc

## ENDING THE LESSON

(An activity to consolidate the language of the lesson.)



### FLASHCARDS (62-66)

Hold up the action flashcards. Ask individual students to answer your questions.

e.g. Teacher: Peter, can you fly?  
Peter: No. etc

### Lesson 7 – Storyland

#### Objectives

To listen to a Russian story in English. To develop listening and speaking skills.

#### Language

In this lesson the students will learn to **understand**:

- Look at the big turnip!

In this lesson the students will learn to **use**:

- pull, turnip, ground

#### Extra Materials

- Flashcard (67) for Presentation & Practice.

## BEGINNING THE LESSON

(An activity to review the story.)

Ask the students if they remember what the previous episode of the story was about. If not ask them to go to the respective page (88) and look at the picture.

## PRESENTATION & PRACTICE

(Activities to present the tale of 'The Giant Turnip'.)



**Listen, point to the picture and repeat.**  
(TRACK 62)



### FLASHCARD (67)

**Students' books closed.** Put up the flashcard on the board. Point to the item on the flashcard (*ground*) and present it. The students repeat after you.

**Students' books open.** Say: Open your books at page a hundred and two. Write the number 102 on the board and hold up your book. Play the recording. The students listen, point and repeat.

#### TAPESCRIPT

Ground.



**Listen to the story. (TRACK 63)**

Direct the students' attention to the picture. Say: Will the mouse help Anna to pull out the turnip? Let's see! Play the recording for the students to listen to the story. Play the recording again. The students listen and point to the characters as they are mentioned. Play the CD a third time with pauses. The students listen and repeat chorally and/or individually.

#### TAPESCRIPT

"Please help us pull out the turnip!" the cat says to the mouse. "Alright, I'm coming," says the mouse. So, the mouse holds the cat. The cat holds the dog. The dog holds Little Anna. Little Anna holds the old woman. The old woman holds the old man. The old man holds the turnip. They pull and pull. The giant turnip pops out of the ground – POP!

## ENDING THE LESSON

(An activity to consolidate the language of the lesson.)

Narrate the story. The students mime it.

### Lesson 8 – Checkpoint

#### Objectives

To consolidate the language of the module.



**Listen and number. (TRACK 64)**

Revise the animals. Explain the activity. Play the recording, twice if necessary. The students listen and number the animals. Check the students' answers.

**Order of animals:** 1 cat, 2 horse, 3 cow, 4 sheep, 5 dog

#### TAPESCRIPT

1 cat  
2 horse  
3 cow  
4 sheep  
5 dog

# Module 7 – My Animals

## ★ 2 Listen and circle. (TRACK 65)

Revise the actions. Explain the activity. Play the recording, twice if necessary. The students listen and circle the actions they hear. Check the students' answers.

**Actions to be circled:** jump, fly, run, swim

### TAPESCRIPT

*Jump, fly, run, swim.*

**Note:** The students are now ready to do Module Test 7.

## Lesson 1

### Objectives

To present and practise the five senses.

### Language

In this lesson the students will learn to **understand**:

- *What can you (smell)?*

In this lesson the students will learn to **use**:

- Senses: *see, smell, hear, taste, touch.*
- *snail, rabbit*
- *I can (see) with my (eyes)!*
- *I can (see) a (snail)!*
- *I can (smell) the ..., but I can't (smell) the ...*

### Extra Materials

- Flashcards (56-66) for the *Beginning the Lesson* activity;
- the *My Senses* poster for *Presentation & Practice*;
- flashcards (68-72) for the *Ending the Lesson* activity.

## BEGINNING THE LESSON

(An activity to review the vocabulary taught in Module 7.)



### FLASHCARDS (56-66)

Hold up an animal flashcard, e.g. *horse*, and say incorrect statements about the animal. Invite the students to respond.

e.g. *Teacher: A horse can fly.*

*Student 1: No! (A horse can't fly!) etc*

## PRESENTATION & PRACTICE

(Activities to present and practise the five senses.)



### Listen, point to the senses and say. (TRACK 66)



### POSTER

**Students' books closed.** Put up the *My Senses* poster on the board. Point to the pictures of the senses, one at a time and say the words, e.g. *see a snail, smell a flower, etc.* The students repeat after you. Point to the senses in random order. The students repeat after you.

**Students' books open.** Say: *Open your books at page a hundred and four.* Write the number 104 on the board and hold up your book. Play the recording. The students listen, point to the senses and repeat, chorally and/or individually. Check their pronunciation and intonation.

### TAPESCRIPT

*See, smell, hear, taste, touch.*



### 1 Draw lines and match. Then, sing. (TRACK 67)

Hold up your book, point to the symbol of the senses and elicit the parts of the face. Then point to the eyes and say: *I can see with my ...*. Invite the students to finish your sentence: *eyes*. Repeat with the rest of the symbols. Explain the activity to the students. Tell them to match the symbols to the corresponding child in the picture. Check the students' answers.

Play the recording. The students listen and point to the parts of their face every time they are mentioned. Play the recording again. The students listen and point to the parts of their face.

### TAPESCRIPT

*I can see with my eyes.  
I can smell with my nose.  
I can taste with my tongue.  
Yummedy, yummedy, yum!*

*I can touch with my hands.  
I can hear with my ears.  
I can do lots of things.  
Yippeedee, yippeedee, dee!*



### 2 Look and find. Then say: *I can (see) a (snail).*

Refer the students to the pictures, point to the items and elicit the words. Explain the activity. Ask the students to locate these items in the picture. Point to the picture of the snail and say: *I can see a snail.* The students repeat after you. Then point to the rest of the pictures and elicit similar sentences involving the five senses, i.e. *I can smell a flower. I can touch a cat. I can taste a banana. I can hear a dog.*



### 3 Look and circle the odd one out. Then, say: *I can (smell) the ..., but I can't (smell) the ...*

Explain the activity. Elicit the names of the items and mime the senses. Ask the students to circle the item we can't smell, hear or taste. Check their answers. Point to the first group of pictures and say: *I can smell the flower and the pizza, but I can't smell the wall.* The students repeat after you. Ask students to make similar sentences orally in class.

**smell:** wall  
**hear:** pencil  
**taste:** green

# Module 8 – My Senses

## (Suggested answers)

*I can hear the cat and the train, but I can't hear the pencil.*

*I can taste the ice cream and the apple, but I can't taste green.*

## ★ 4 Draw something you can hear, touch, smell, taste and see. Tell the class.

Refer the students to the picture and ask them to draw something they can *hear, see, smell, touch, taste* in the corresponding box. Then ask them to present their picture to the class. Demonstrate this yourself first.

### Variation

The students can make a *My Senses* poster. On a big piece of construction paper students draw things they can *see, hear, taste, touch* and *smell*.

## ENDING THE LESSON

*(An activity to consolidate the language of the lesson.)*



### FLASHCARDS (68-72)

Put up the flashcards on the board. Point to each one and invite individual students to say which of the five senses they depict.

*e.g. Teacher: (pointing to the 'smell' flashcard)*  
*Student 1: Smell! etc*

### WORKBOOK (Optional)

If you wish, you can do Exs 1 and 2 from the *Workbook* during this lesson or the next one.

## Lesson 2

### Objectives

To present and practise the concept of day and night. To explore other subject areas: Science.

### Language

In this lesson the students will learn to **understand**:

- *Is it (day) or is it (night)?*

In this lesson the students will learn to **use**:

- *sun, moon, day, night, stars*
- *It's day/night!*

### Extra Materials

- Flashcards (73-77) for *Presentation & Practice*;
- A4 sheets of paper for each student for the *Ending the Lesson* activity.

## BEGINNING THE LESSON

*(An activity to review the five senses.)*

Mime one of the five senses. The students have to guess what it is.

*e.g. Teacher: (mimes tasting)*  
*Student 1: taste! etc*

## PRESENTATION & PRACTICE

*(Activities to present and practise the concept of day and night.)*



### ★ Listen, point to the items and say. (TRACK 68)



### FLASHCARDS (73-77)

**Students' books closed.** Put up the flashcards on the board. Point to the items (*sun, moon, day, night, stars*), one at a time, and say the word. The students repeat after you. Point to the items in random order. The students repeat after you.

**Students' books open.** Say: *Open your books at page a hundred and six.* Write the number 106 on the board and hold up your book. Play the recording. The students listen, point and repeat.

### TAPESCRIPT

*Sun, moon, day, night, stars.*



### ★ 1 DAY or NIGHT? Look at the pictures and draw. Then, say: *It's day/night.*

Refer the students to the picture, point to the corresponding part and elicit *day and night – sun and moon*. Explain the activity. The students look at the pictures and draw a *sun* (if the action usually takes place during the day) or a *moon* (if it usually takes place at night). Then, students point to the pictures and say, *e.g. It's day.*

**ride a bike:** It's day.

**sleep:** It's night.

**go to school:** It's day.

**take a bath:** It's night.

**watch TV:** It's night.

**go swimming:** It's day.



### ★ 2 Listen and sing. (TRACK 69)

Hold up your book and ask as you point to the corresponding part of the picture and say: *Is it dark or is it light?* The students repeat after you. Then ask: *Is it*

*day or is it night?* The students repeat after you. Repeat with the rest of the lyrics. Play the recording. The students listen and look. Play the recording again. The students listen and sing along.

## TAPESCRIPT

*Is it dark or is it light?  
Is it day or is it night?  
Sun or moon,  
Moon or sun,  
Looking down at everyone.*

### 3 Play the **Guessing game**.

Explain the game. Ask a student to come to the front and mime an action that takes place during the day or at night. The rest of the class has to guess whether it is *day* or *night*. The first student to answer correctly takes the next turn.

## ENDING THE LESSON

*(An activity to review the concept of day/night.)*

Provide each student with a sheet of paper and ask them to draw an action that takes place during the day or night and present it to the class by saying: *It's day/night!* Demonstrate this yourself first.

## WORKBOOK (Optional)

If you wish, you can do Exs 3 and 4 from the *Workbook* during this lesson or the next one.

### Lesson 3

#### Objectives

To listen to a story about the characters enjoying themselves at a fairy party. To develop listening comprehension skills through a dialogue.

#### Language

In this lesson the students will learn to **understand**:

- *Who's this?*

In this lesson the students will learn to **use**:

- *I can (see the moon)!*
- *It's a fairy party!*
- *This is fun!*
- *I love the Magic Forest!*

#### Extra Materials

- The *My Senses* poster for *Presentation & Practice*.

## BEGINNING THE LESSON

*(An activity to review the concept of day/night.)*

Play the song from the previous lesson (Track 69). The students listen and sing along.

## PRESENTATION & PRACTICE

*(Activities to present the story and develop students' listening skills.)*

### 1 Listen to the story and point to the pictures. (TRACK 70)



#### POSTER

**Students' books closed.** Use the *My Senses* poster to present the story. Explain to the students, in L1 if necessary, that Woody and Frosty are going to a fairy party. Point to Woody in the first picture and ask: *Who's this?* Elicit: *Woody*. Say, as you point to the moon: *Look, Frosty! I can see the moon!* The students repeat after you. Point to the music notes in the second picture and say: *Listen! I can hear music!* The students repeat after you. Repeat with the rest of the pictures.

**Students' books open.** Say: *Open your books at page a hundred and eight.* Write the number 108 on the board and hold up your book. Ask students to identify the characters and any items they know.

*e.g. Student 1: (pointing to the moon in Frame 1) (This is) the moon! etc*

Play the recording and ask the students to point to each picture in their book in turn. Show them what to do by holding up your book and pointing. Play the recording again. The students listen and repeat, chorally and/or individually.

Point to the first picture on the poster. Ask the students to complete your sentences.

*e.g. Teacher: Look, Frosty! I can see the ...  
Class: moon! etc*

#### Extension

Ask for a volunteer to come and point to the first picture on the poster. Encourage him/her to say the dialogue. Ask the rest of the class for verification. Repeat with different students for the rest of the story.

## TAPESCRIPT

### Frame 1

*Woody: Look, Frosty! I can see the moon!*

# Module 8 – My Senses

## Frame 2

Frosty: Listen! I can hear music!

## Frame 3

Woody: I can smell popcorn!

## Frame 4

Frosty: I can see Erlina!

## Frame 5

Frosty: Wow! It's a fairy party!

## Frame 6

Alvin: Frosty! Woody! Come on!

## Frame 7

Willow: This is fun!

## Frame 8

Woody: I love the Magic Forest!

Read the question at the bottom of page 109. Ask the students to draw a happy face or a sad face depending on whether they like the story or not. Ask them to tell you, in L1 if necessary, what they like most.

## ENDING THE LESSON

(An activity to consolidate the language of the lesson.)

Tell the students to make an invitation for the fairy party. If you wish, you can write the following on the board and ask the students to copy it on a piece of paper and decorate the invitation.

Dear ...

Please come to our fairy party!

Love,

...

### Lesson 4

#### Objectives

To talk about animals we can see at night.

#### Language

In this lesson the students will learn to **understand**:

- *What can you see?*
- *koala, snail, bat, mouse, lion*

In this lesson the students will learn to **use**:

- *I can see a (bat) at night.*

#### Extra Materials

- Egg cartons and some elastic for each student for Ex. 2 (refer to *Before going into class*);
- pictures of day & night animals for the *Ending the Lesson* activity.

## BEGINNING THE LESSON

(An activity to revise the language from the previous lesson.)

Play the dialogue from the previous lesson (Track 70). The students listen and follow in their books.

## PRESENTATION & PRACTICE

(Activities to talk about animals we can see at night.)

**1** Look at the animals and say: *I can see a (snail at night).*

**Students' books closed.** Draw a simple sketch of a bat and a moon on the board. Ask students in L1 to tell you what they can see. Elicit the answer. Then point to the bat and say: *I can see a bat at night.* Students repeat after you. Ask students, in L1 if necessary, what other animals they know that they can see at night.

**Students' books open.** Say: *Open your books at page a hundred and ten.* Write the number 110 on the board and hold up your book. Point to the picture of the koala and say: *koala.* Then say: *I can see a koala at night.* The students repeat after you. Then students look at the pictures and make similar sentences orally in class.

I can see a bat at night.

I can see a mouse at night.

I can see a lion at night.

I can see a snail at night.

**2** Let's make a bat!

### Before going into class

You need 3 sections of an egg carton for each bat.

Guide the students in making their bats.

#### Directions

Cut the cartons up. Using a pair of scissors, make a small hole into the head of the bat. Thread the elastic through and tie a knot. This will enable the bat to bounce around!!



Then draw a pair of eyes and a mouth. The bat is ready!



**Note:** You can show the students how to make the bat and ask them to do it at home and bring it to the class for the next lesson.

## 3 Colour the animals you can see at night blue.

Explain the activity. Point to and elicit the names of the animals. Point to the bat and ask: *Day or night?* Elicit the right response (*night*). Allow the students some time to colour in the bat blue. Go through the rest of the animals and elicit the night-time animals. Allow the students some time to colour them blue. Check the students' answers.

**Animals to be coloured:** bat, lion, cat

## ENDING THE LESSON

(An activity to consolidate the language of the lesson.)

### Before going into class

Bring in pictures of day-time and night-time animals.

Show the students the pictures of the animals you have brought, one at a time. The students look at them and say *day* if they are day-time animals or *night* if they are night-time animals.

## Lesson 5

### Objectives

- To consolidate the language learnt in the module.
- To make a collage of things connected with day or night.

### Language

In this lesson the students will learn to **understand**:

- (*Alvin*), *what can you see?*
- Is it day or night?*

In this lesson the students will learn to **use**:

- It's (night). I can see (the (moon, the stars, a bat).*

### Extra materials

- A4 sheets of paper for each student for Ex. 4.

## BEGINNING THE LESSON

(An activity to review the senses.)

Say a sentence. The students correct it if it's incorrect.

e.g. *Teacher: I can touch the sun.*

*Students: No.*

*Teacher: I can see the sun.*

*Students: Yes. etc*

## PRACTICE

(Activities to consolidate the vocabulary of the module.)

## 1 Listen and draw lines. (Track 71)

Say: *Open your books at page a hundred and twelve.* Write the number 112 on the board and hold up your book. Refer the students to the picture and elicit the items and the senses. Play the recording, twice if necessary. The students listen and draw lines to match the items to the corresponding senses. Check their answers.

Dog – hear

Apple – taste

Snail – see

Flower – smell

Ice cream – touch

### TAPESCRIPT

*I can hear a dog.*

*I can taste an apple.*

*I can see a snail.*

*I can smell a flower.*

*I can touch an ice cream.*

## 2 Make your Senses Book.

Point to and explain the craftwork. Guide the students through the following steps:



The students fold a piece of paper and divide it into five columns.

2

Then they draw symbols for the five senses.

3

They cut along the lines.

# Module 8 – My Senses

4

Students attach a photo or a drawing in each column.

Allow the students some time to make their Senses Book. Alternatively, explain the activity and assign it as homework.

## ★ 3 Listen and draw lines. Then, say: (*Alvin*), what can you see? I can see the ... . (TRACK 72)

Elicit the names of the items by pointing and asking: *What's this?* Play the recording, twice if necessary. The students listen and draw lines. Then students take roles and ask and answer.

### TAPESCRIPT

- 1 **Boy:** *Alvin, what can you see?*  
**Alvin:** *I can see the cat.*
- 2 **Boy:** *Erlina, what can you see?*  
**Erlina:** *I can see the stars.*
- 3 **Boy:** *Woody, what can you see?*  
**Woody:** *I can see the bat.*
- 4 **Boy:** *Frosty, what can you see?*  
**Alvin:** *I can see the moon.*

## ★ 4 Portfolio: Draw a picture of day or night. Present it to the class. Say: *It's (night). I can see (the moon, the stars, a bat).*

(An activity to develop fine motor skills and consolidate the language of the module.)

Point to the picture and ask: *Is it day or night?* Elicit the answer (*It's night*). Then ask: *What can you see?* Elicit: *I can see the moon, the stars, a bat.* Provide each student with a sheet of paper. Ask the students to draw a similar picture of night or day and present it to the class. Make sure you display their work somewhere in the class. Then help them file their drawings in their *Junior Language Portfolios*.

### ENDING THE LESSON

(An activity to consolidate the language of the lesson.)

Have the students stand up. Say: *It's day.* The students think of an action that usually takes place in the day and mime doing it. Repeat with *It's night.*

### WORKBOOK (Optional)

If you wish, you can do Exs 5-6 from the *Workbook* during this lesson or the next one.

## Lesson 6 – Our World/My World

### Objectives

To familiarise students with British, Italian and Russian culture. To talk about things you can see, taste, hear in the UK/Italy/Russia.

### Language

In this lesson the students will learn to **understand**:

- *UK, Italy, Russia*
- *Big Ben, fish and chips, bagpipes, Coliseum, violin, St. Basil's Cathedral, balalaika*

In this lesson the students will learn to **use**:

- *I can see..., I can taste..., I can hear...*

### Extra Materials

- A map of the world for Ex. 1 (Optional);
- A4 sheets of paper for each student for the *Ending the Lesson* activity.

## BEGINNING THE LESSON

(An activity to review the senses.)

Ask the students to present the drawings they made in the previous lesson.

## OUR WORLD

(Activities to familiarise students with aspects of British and Italian culture.)

## ★ 1 Trace the pictures. Then say: *I can see ..., I can taste ..., I can hear ...*

**Students' books open.** Say: *Open your books at page a hundred and fourteen.* Write the number 114 on the board and hold up your book. Point to the British flag and elicit the country: *UK.* Explain to the students that in this section they will talk about famous landmarks (*things we can see*), food (*things we can taste*) and musical instruments (*things we can hear*) in Britain. Ask them to trace the picture of *Big Ben* with their pencils. Point to the picture and tell students that this is one of Britain's best-known landmarks. Then say: *I can see Big Ben.* The students repeat after you. Then point to the picture of the *fish and chips* and tell the students that this is a popular food in Britain. Say: *I can taste fish and chips.* The students repeat after you. Finally, show them

the bagpipes and say: *I can hear the bagpipes*. The students repeat after you.

Next, point to the Italian flag. If you have a map of the world, put it up on the board and show where *Italy* is. Ask the students if they know anything about Italy and have a class discussion in L1 (e.g. *famous people, cities, landmarks, food, etc*). Point to the picture of the *Coliseum* and say: *I can see the Coliseum*. Then point to the pictures of the *pizza* and the *violin* and ask the students to trace the *pizza* with their pencils. Then encourage students to say: *I can taste pizza. I can hear the violin*.

## MY WORLD

(Activities for the students to explore and talk about their own culture in English.)

### ★ 2 What can you see/hear/taste in your country? Complete the pictures, point and say.

Point to *St Basil's Cathedral* and elicit its name in L1 and then say its name in English. Repeat with *balalaika* and *shi*. Allow the students some time to complete the picture and then say what they can see, hear and taste in their country. Check the students' answers. As an extension, the students can say more things they can see/hear/taste in their country and even make a collage.

### ★ 3 Play the *Chinese Whispers* game.

Tell the students they are going to play *Chinese Whispers*. Explain the rules. Ask the students to form a circle and begin the game by whispering a word to a student. Tell him/her to whisper the word to the student next to them. Then he/she passes it on to the student next to them in the same way as before, around the circle of students. When it gets to the last person to have the word whispered to them, they have to say what they think the word was. If it is correct, then you may do some kind of fun activity to celebrate the fact that the students got it right. Repeat the game with other words.

## ENDING THE LESSON

(An activity to consolidate the language of the lesson.)

Provide each student with a sheet of paper. Ask them to choose one of the five senses and draw it. Then they present their drawings to the class.

## Lesson 7 – Storyland

### Objectives

To listen to a Russian story in English. To develop listening and speaking skills.

### Language

In this lesson the students will learn to **understand**:

- *Look at the big turnip!*

In this lesson the students will learn to **use**:

- *pull, turnip, ground*

### Extra Materials

- Flashcard (78).

## BEGINNING THE LESSON

(An activity to review the story.)

Ask the students if they remember what the previous episode of the story was about. If not ask them to go to the respective page (102) and look at the picture.

## PRESENTATION & PRACTICE

(Activities to present the tale of 'The Giant Turnip'.)

### ★ Listen, point to the picture and repeat. (TRACK 73)



FLASHCARD (78)

**Students' books closed.** Put up the flashcard on the board. Point to the item on the flashcard (*fall*) and present it. The students repeat after you.

**Students' books open.** Say: *Open your books at page a hundred and sixteen*. Write the number 116 on the board and hold up your book. Play the recording. The students listen, point and repeat.

### TAPESCRIPT

*Fall.*

### ★ Listen to the story. (TRACK 74)

Direct the students' attention to the picture. Point to the characters and present them.

Play the recording for the students to listen to the story. Play the recording again. The students listen and point to the characters as they are mentioned. Play the CD a third time with pauses. The students listen and repeat, chorally and/or individually.

# Module 8 – My Senses

## TAPESCRIPT

The old man falls on the old woman. The old woman falls on Little Anna. Little Anna falls on the dog. The dog falls on the cat. The cat falls on the mouse! It is very funny! "Thank you for your help," says the old man. "Let's all eat the great big turnip!"

### ★ 1 Listen and sing. (TRACK 75)

Ask the students to look at the pictures. Ask the students to say, in L1 if necessary, what the story is about (helping others). Say: *A little help goes a long long way.* The students repeat after you. Follow the same procedure and present the rest of the song.

Play the recording. The students listen. Play the recording again. The students listen and sing along.

## TAPESCRIPT

*A little help  
Goes a long long way  
A long long way, a long long way!  
A little help  
Goes a long long way  
Give a little help today!*

*Hold on tight  
To help a friend  
Hold on tight, hold on tight!  
Hold on tight  
To help a friend  
Give your friends a helping hand!*

## ENDING THE LESSON

*(An activity to consolidate the language of the lesson.)*

Ask the students to form a circle. If you wish you can provide them with a piece of rope. Play the song. The students sing along as they move around in the circle.

### Lesson 8 – Checkpoint

#### Objectives

To consolidate the language of the module.

### ★ 1 Listen and circle. (TRACK 76)

Explain the activity. Play the recording, twice if necessary. The students listen and number the actions heard. Check the students' answers.

**Pictures to be circled:** 2, 3, 5

## TAPESCRIPT

*I can hear music.  
I can smell a flower.  
I can touch a cat.*

### ★ 2 Look at the pictures and (✓) or (X). Then, say.

Explain the activity. Allow the students some time to complete the activity. Check the students' answers.

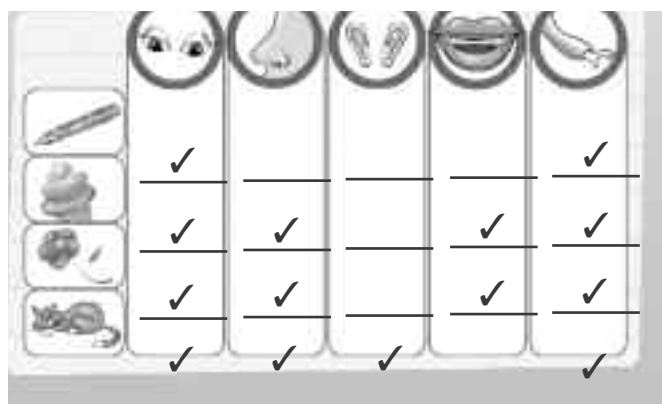

**Note:** The students are now ready to do Module Test 8.

## Objectives

To consolidate the key vocabulary of the course.

## Vocabulary

apples, ball, bananas, bed, biscuits, book, car, cat, cheese, chair, climb, cola, cow, cupboard, dog, doll, door, ears, eggs, eyes, floor, fly, hair, hear, hen, horse, house, ice cream, jump, milk, moon, mouth, nose, pen, pencil, pencil case, pizza, plane, popcorn, roof, rubber, run, sandwiches, schoolbag, see, sheep, smell, stars, sun, swim, table, taste, tea, teddy, teeth, tongue, touch, train, wall, window.

**Note:** *Fun Time!* aims to consolidate the vocabulary of the course. The teacher can spend some time at the end of the school year on this section. Alternatively, the teacher can cover the section gradually upon completion of every module.

## PROCEDURE

Have a class discussion. Hold up your book, point to an item, e.g. *bananas*, and ask: *What colour are they?* Elicit: *Yellow*. Then ask: *What are they?* Elicit: *Bananas. etc.*

Here are some suggested games/activities the teacher can do with the students.



### I. I SPY ...

Ask the students to look at the picture. Divide the class into two teams, A and B. Explain the game. You say a letter and the students in teams take turns finding an item in the picture. Each correct answer gets one point. The team with the most points wins.

e.g. Teacher: *I spy with my little eye, something beginning with (a) /æ/.*  
 Student 1 Team A: *Apples!*  
 Teacher: *Correct! 1 point for Team A. etc*

### II. Categories

Draw some columns on the board, e.g.

Ask the students to work in pairs/groups and find more items in the picture that can go with the ones given. They can circle the items in the picture, put a tick or draw simple sketches in their notebooks. Ask the pairs/groups to report back to the class.

e.g. **apples:** *bananas, sandwiches, biscuits, cheese, tea ... (food/drink items)*  
**pen:** *schoolbag, pencil, pencil case, rubber, book ... (school items)*  
**bed:** *cupboard, table, chair, roof ... (things in a house and parts of the house)*

### III. Mime the word

Ask the students to look at the picture. Divide the class into two teams, A and B. Explain the game. Mime one of the items in the picture and the students in teams take turns finding which item it is. Each correct answer gets one point. The team with the most points wins.

e.g. Teacher: *(mimes sleeping)*  
 Student 1 Team A: *Bed!*  
 Teacher: *Correct! 1 point for Team A. etc*

### IV. Words in a heart

Draw a big heart on the board. Ask the students to do the same in their notebooks. Ask the students to draw in the hearts the items they like, want to have, etc. Then students present their drawings.

### V. Number the words

#### Before going into class

Prepare sheets of paper, one per group, with different items from the picture on pages 120-121, e.g.

#### Sheet 1



#### Sheet 2



# Fun Time!

Divide the class into groups. Give a sheet of paper to each group. Explain the activity. The groups find the items on their sheets in the picture and number them. The group that finishes first is the winner.

## VI. Telepathy

Divide the class into two teams, A and B. Think of an item and say the name of the module, e.g. *My Schoolbag*. The teams take turns finding which item it is. Each correct answer gets one point. The team with the most points wins.

e.g. Teacher: (thinks of pen) *My Schoolbag*.  
Student 1 Team A: (Is it) a book?  
Teacher: No!  
Student 1 Team B: (Is it) a pen?  
Teacher: Yes! 1 point for Team B. etc



## Objectives

- To talk about Christmas. To sing a Christmas song.
- To make Christmas decorations.

## Language

In this lesson the students will learn to **understand**:

- It's Christmas time! Merry Christmas!*
- Santa, reindeer, Christmas tree, presents, sleigh*
- What's this?*

In this lesson the students will learn to **use**:

- Merry Christmas!*
- Jingle Bells!*
- It's a (ball).*
- A (ball) for (Alvin)!*
- Thank you!*

## Extra Materials

- A big Christmas tree made out of green paper for the class for the *Beginning the Lesson* activity;
- pictures/photographs related to Christmas (*Santa, reindeer, Christmas tree, presents, sleigh*) for *Presentation & Practice*;
- A4 sheets of paper for each student for Ex. 4;
- photocopies of the Christmas decorations template (p. 119) for each student for Ex. 4 (*Extension*).

**Note:** This unit is optional. It is designed to be taught just before Christmas.

## BEGINNING THE LESSON

(An activity to present Christmas.)

### Before going into class

Make a big Christmas tree out of green paper.

Put up the big Christmas tree you have prepared on the board and say: *A Christmas tree*. The students repeat, chorally and/or individually. Tell them: *It's Christmas time! Merry Christmas!* The students repeat after you.

## PRESENTATION & PRACTICE

(Activities to present and practise a Christmas song.)

### 1 Sing. (TRACK 77)

### Before going into class

Bring in pictures related to Christmas.

**Students' books closed.** Put up the pictures/photographs related to Christmas on the board. Point to the pictures (*Santa, reindeer, Christmas tree, presents, sleigh*), one at a time, and say the word(s). The students repeat after you. Point to the pictures in random order. The students repeat after you.

**Students' books open.** Say: *Open your books at page a hundred and twenty-two*. Write the number 122 on the board and hold up your book. Hold up your book, point to the pictures and elicit the words. Play the recording as many times as you think necessary for the students to start singing along.

## TAPESCRIPT

*Jingle Bells,  
Jingle Bells,  
Jingle all the way!  
Oh, what fun it is to ride  
On a one-horse open sleigh!*

### 2 Find the items in the picture and colour them.

Refer the students to the pictures, point to the items and elicit the words. Explain the activity. Ask the students to find these items in the picture (Ex. 1) and colour them.

### 3 Choose a present for each character. Then say: *A (ball) for (Alvin)*.

Point to each present and say: *What's this?* Elicit: *It's a (ball)*. Explain the activity. Write on the board: *Erlina, Alvin, Woody, Frosty, Willow* (alternatively, put up the *Hello!* poster). Tell the students that they will choose a present for each character in the book. Demonstrate this yourself first. Point to the ball and say: *A ball for Alvin*. The students repeat after you. Then ask individual students to say for which character each present is.

## Extension

Point to a present, then to a student and say: *A (doll) for you! Merry Christmas!* Elicit: *Thank you!* Ask the students, in pairs, to choose a present for their partner and repeat the same pattern.

e.g. *Student 1: A teddy for you! Merry Christmas!*  
*Student 2: Thank you! etc*

### 4 Make a card for the holidays. Offer it to your mum and dad.

Refer the students to the Christmas card. Provide each student with a sheet of paper. Ask the students to fold the paper in half to make a card. Ask them to decorate their cards for their mum and dad. Alternatively, assign

# Season's Greetings!

it as homework. During the activity, you may play the *Jingle Bells* song.

## Extension

### Before going into class

Have the photocopies of the Christmas template, one per student, ready to use.

Ask the students to colour and cut the Christmas decorations. Once they have finished, tell them to use their decorations to decorate the Christmas tree that is on the board, or take them home and decorate their room, etc. During the activity, you may play the *Jingle Bells* song as many times as you wish.

## ENDING THE LESSON

*(An activity to consolidate the language related to Christmas.)*

As the students leave, invite them to say *Merry Christmas!*

## Objectives

To talk about Mother's Day.

## Language

In this lesson the students will learn to **understand**:

- *Mother's Day*
- *love, kisses, hugs*

In this lesson the students will learn to **use**:

- *This flower is for you, Mum.*
- *Happy Mother's Day!*
- *Oh, thank you!*
- *heart*

## Extra Materials

- A4 sheets of paper for each student for Ex. 2 (*Extension*);
- a straw and two sheets of coloured paper (one of them green) for each student for Ex. 4.

**Note:** This unit is optional. It is designed to be taught just before Mother's Day.

## BEGINNING THE LESSON

(Activities to present Mother's Day.)

Write the date of the Mother's Day celebration on the board and encourage the students to guess why that date is special. Have a general discussion, in L1, about how they usually celebrate Mother's Day.

## PRESENTATION & PRACTICE

(Activities to present the concept of Mother's Day.)



### 1 Listen and sing. (TRACK 78)

**Students' books closed.** Draw a picture of a woman's face on the board and say the word(s) *Mummy/Mum/Mother*. Ask the students to tell you what words come to mind when they think of their mums. This is a good opportunity to teach the students some new words, e.g. *love, kisses, hugs, etc.*

**Students' books open.** Say: *Open your books at page a hundred and twenty-four.* Write the number 124 on the board and hold up your book. Read the title and say/ elicit what it means. Hold up your book, point to the pictures and elicit the words (*butterfly, snail, flower, boy, mum*).

Play the recording as many times as you think necessary for the students to start singing along. Encourage the students to do the actions.

## TAPESCRIPT

*Oh, Mother, Mother, (hug yourself)*

*Mummy, Mum!*

*Your love to me (make an imaginary circle with both hands)*

*Is like the sun!*

*It's warm and happy*

*With a smiling face! (mime painting an imaginary smile on your face)*

*No other, Mother*

*Can take your place! (stretch both arms in front of you)*



### 2 Look and match the hearts.

Point to one of the hearts and say: *heart*. The students repeat after you. Explain the activity. The students look and match the hearts. Check their answers.

## Extension

Provide each student with a sheet of paper. Write the word 'LOVE' on the board and ask the students to copy it. Encourage the students to draw all the things that come to mind when they think about love. Go around the classroom asking the students questions about their pictures.



### 3 Help the child get to her mother.

Point to the girl and ask the students to say what she is holding. Elicit: *flowers*. Explain the activity. Tell the students they have to help the child get to her mum. The students solve the maze by finding the correct path to the finish point. Check the students' answers.



### 4 Make a bunch of flowers for your mum.

#### Before going into class

Bring a straw and two sheets of coloured paper (one of them green) for each student.

Tell the students that they are going to make a bunch of flowers for their mums. Show them your model. Guide them through the cutting and colouring of their templates. Go around the classroom as the students make their flowers and ask questions about the colours the students have used.

## Materials for each student:

- two sheets of coloured paper (one of them green)
- a straw
- glue
- scissors

# Mother's Day!



## Instructions:

Trace your hand on coloured paper and cut it out.



Draw some leaves on green paper, then cut them out.



Curl each of the fingers around a pencil.



Glue both sides together and stick the flower onto a straw.



Then, stick the leaves onto the straw.



## ENDING THE LESSON

(An activity to consolidate the language of the lesson.)

Invite the students to show their flowers to the class. Ask a student to take on the role of 'Mother' and ask the rest of the students to offer a flower to her. Demonstrate this yourself first.

e.g. Student 1: *This flower is for you, Mum. Happy Mother's Day!*

Mother: *Oh, thank you! etc*

## Aa-Bb

### Objectives

introducing the alphabet (Aa-Bb)

### Language

*apple, bed*

### Extra Materials

- *My Alphabet* poster;
- photocopies of the word cards *apple* and *bed*;
- photocopies of the *Aa-Bb Alphabet Worksheets*.

## PRESENTATION & PRACTICE

(Activities to present the letters A-B.)



POSTER

### 1 Listen and repeat. Then, colour. (TRACK 79)

**Students' books closed.** Put up *My Alphabet* poster on the board. Point to the letters *A, B* and say the appropriate sounds. The students repeat chorally and individually. Point to the pictures and say the words. The students repeat chorally and/or individually.

**Students' books open.** Play the recording. The students listen to the letter sounds and the words and repeat chorally and individually. Individual students read the letters and the words. Then, students colour in the letters in the pictures.

### 2 Write the letters.

(Activities to practise writing the letters of the alphabet.)

Refer the students to the letters in Ex.2. Hold up your book and demonstrate how to use the arrows as guides to write each letter. Explain that they have to copy each letter twice, upper and lower case. Allow students some time to complete the task. Go around the classroom, giving help where necessary.

### 3 Draw lines.

Ask the students to look at the picture. Read the instructions and explain the task. Allow students enough time to complete the activity. Go around the classroom, giving help where necessary. Check students' answers.

## ENDING THE LESSON

(An activity to revise the alphabet.)

### Before going into class

Photocopy the word cards: *apple, bed*.

Write the letters *A, B* on the board. Hand out the photocopies of the word cards. Ask the students to come to the board and stick their word card under the correct letter. Ask the rest of the class for verification.

**Note:** For further practice on the alphabet, you can hand out the photocopies of the corresponding *Alphabet Worksheets*.

## Cc-Dd

### Objectives

introducing the alphabet (Cc-Dd)

### Vocabulary

*cat, dog*

### Extra Materials

- *My Alphabet* poster;
- photocopies of the word cards *apple, bed, cat, dog*;
- photocopies of the *Cc-Dd Alphabet Worksheets*.

## PRESENTATION & PRACTICE

(Activities to present the letters C-D.)

### 1 Listen and repeat. Then, colour. (TRACK 80)



POSTER

**Students' books closed.** Put up *My Alphabet* poster on the board. Revise letters *A, B* and the corresponding words. Then, point to the letters *C, D* and say the appropriate sounds. The students repeat chorally and individually. Point to the pictures and say the words. The students repeat chorally and individually.

**Students' books open.** Play the recording. The students listen to the letter sounds and the words and repeat chorally and individually. Individual pupils read the letters and the words. Then, students colour in the letters in the pictures.

## ★ 2 Write the letters.

(Activities to practise writing the letters of the alphabet.)

Refer the students to the letters in Ex.2. Hold up your book and demonstrate how to use the arrows as guides to write each letter. Explain that they have to copy each letter once, upper and lower case. Allow students some time to complete the task. Go around the classroom, giving help where necessary.

## ★ 3 Listen and circle the words that begin with c and d. (TRACK 81)

Read the instructions and explain the task. Point to the first letter and say: C. Students repeat after you chorally. Repeat the procedure with D. Play the recording. Students listen and circle the words that start with c or d. Allow students some time to complete the task. Go around the classroom, giving help where necessary. Check students' answers.

**c:** cat, cow

**d:** duck

## ★ 4 Find and circle the letters a, b, c and d.

Ask the students to look at the picture. Read the instructions and explain the task. Allow the students enough time to complete the activity. Go around the classroom, giving help where necessary. Check students' answers.

## ENDING THE LESSON

(An activity to revise the alphabet.)

### Before going into class

Photocopy the word cards: *apple, bed, cat, dog.*

Write the letters A-D on the board. Hand out the photocopies. Ask the students to come to the board and stick their word card under the correct letter. Ask the rest of the class for verification.

**Note:** For further practice on the alphabet, you can hand out the photocopies of the corresponding *Alphabet Worksheets.*

## Ee-Ff

### Objectives

introducing the alphabet (Ee-Ff)

### Vocabulary

*egg, fish*

### Extra Materials

- *My Alphabet* poster;
- photocopies of the word cards *apple, bed, cat, dog, egg, fish*;
- photocopies of the *Ee-Ff Alphabet Worksheets.*

## PRESENTATION & PRACTICE

(Activities to present the letters E-F.)

## ★ 1 Listen and repeat. Then, colour. (TRACK 82)



POSTER

**Students' books closed.** Put up *My Alphabet* poster on the board. Revise letters A-D and the corresponding words. Then, point to the letters E, F and say the appropriate sound. The students repeat chorally and individually. Point to the pictures and say the words. The students repeat chorally and individually.

**Students' books open.** Play the recording. The students listen to the letter sounds and the words and repeat chorally and individually. Individual pupils read the letters and the words. Then, students colour in the letters in the pictures.

## ★ 2 Write the letters.

(Activities to practise writing the letters of the alphabet.)

Refer the students to the letters in Ex. 2. Hold up your book and demonstrate how to use the arrows as guides to write each letter. Explain that they have to copy each letter twice, upper and lower case. Allow students some time to complete the task. Go around the classroom, giving help where necessary.

## ★ 3 Circle the odd one out.

Read the instructions and explain the task. Students read the letters and circle the odd one out. Allow students some time to complete the task. Go around the classroom, giving help where necessary. Check students' answers.

- |     |     |     |     |
|-----|-----|-----|-----|
| 1 F | 3 F | 5 f | 7 F |
| 2 E | 4 A | 6 A | 8 A |



## ★ 4 Find the letters to complete the words. Then, draw a picture.

Read the instructions and explain the task. Students find the letters and complete the words (fish, egg). Then they draw an egg and a fish. Allow students some time to complete the task. Go around the classroom, giving help where necessary. Check students' answers.

- 1 fish                      2 egg

## ENDING THE LESSON

(An activity to revise the alphabet.)

### Before going into class

Photocopy the word cards: *apple, bed, cat, dog, egg, fish.*

Write the letters A-F on the board. Hand out the photocopies. Ask the students to come to the board and stick their word card under the correct letter. Ask the rest of the class for verification.

**Note:** For further practice on the alphabet, you can hand out the photocopies of the corresponding *Alphabet Worksheets*.

### Gg-Hh

#### Objectives

introducing the alphabet (Gg-Hh)

#### Vocabulary

*glass, hen*

#### Extra Materials

- *My Alphabet* poster;
- photocopies of the word cards *apple, bed, cat, dog, egg, fish, glass, hen*;
- photocopies of the *Gg-Hh Alphabet Worksheet*.

## PRESENTATION & PRACTICE

(Activities to present the letters G-H.)

## ★ 1 Listen and repeat. Then, colour. (TRACK 83)



POSTER

**Students' books closed.** Put up *My Alphabet* poster on the board. Revise letters A-F and the corresponding

words. Then, point to the letters G, H and say the appropriate sound. The students repeat chorally and individually. Point to the pictures and say the words. The students repeat chorally and individually.

**Students' books open.** Play the recording. The students listen to the letter sounds and the words and repeat chorally and individually. Individual pupils read the letters and the words. Then, students colour in the letters in the pictures.

## ★ 2 Write the letters.

(Activities to practise writing the letters of the alphabet.)

Refer the students to the letters in Ex.2. Hold up your book and demonstrate how to use the arrows as guides to write each letter. Explain that they have to copy each letter twice, upper and lower case. Allow students some time to complete the task. Go around the classroom, giving help where necessary.

## ★ 3 Match the upper case with the lower case.

Read the instructions and explain the task. Students match the upper case with the lower case letters. Allow students some time to complete the task. Go around the classroom providing help where necessary. Check students' answers.

Aa    Bb    Cc    Dd    Ee    Ff    Gg    Hh

## ★ 4 Use the code to colour the picture.

Read the instructions and explain the task. Students read the code and colour in the picture. Allow students some time to complete the task. Go around the classroom, giving help where necessary. Check students' answers.

## ENDING THE LESSON

(An activity to revise the alphabet.)

### Before going into class

Photocopy of the word cards: *apple, bed, cat, dog, egg, fish, glass, hen.*

Write the letters A-H on the board. Hand out the photocopies. Ask the students to come to the board and stick their word card under the correct letter. Ask the rest of the class for verification.

**Note:** For further practice on the alphabet, you can hand out the photocopies of the corresponding *Alphabet Worksheets*.

## li-Jj

### Objectives

introducing the alphabet (li-Jj)

### Vocabulary

*iguana, jug*

### Extra Materials

- *My Alphabet* poster;
- photocopies of the word cards *apple, bed, cat, dog, egg, fish, glass, hen, iguana, jug*;
- photocopies of the *li-Jj Alphabet Worksheet*.

## PRESENTATION & PRACTICE

(Activities to present the letters I-J.)



**1 Listen and repeat. Then, colour. (TRACK 84)**



POSTER

**Students' books closed.** Put up *My Alphabet* poster on the board. Revise letters *A-H* and the corresponding words. Then, point to the letters *I, J* and say the appropriate sound. The students repeat chorally and/or individually. Point to the pictures and say the words. The students repeat chorally and individually.

**Students' books open.** Play the recording. The students listen to the letter sounds and the words and repeat chorally and individually. Individual pupils read the letters and the words. Then, students colour in the letters in the pictures.



**2 Write the letters.**

(Activities to practise writing the letters of the alphabet.)

Refer the students to the letters in Ex.2. Hold up your book and demonstrate how to use the arrows as guides to write each letter. Explain that they have to copy each letter twice, upper and lower case. Allow students some time to complete the task. Go around the classroom, giving help where necessary.



**3 Match. Colour.**

Read the instructions and explain the task. Students match the letters. Then they colour in the jugs accordingly. Allow students some time to complete the task. Go around the classroom, giving help where necessary. Check students' answers.

li Jj



**4 Look at the pictures and complete the words. Read them to your friend.**

Refer the students to the pictures and elicit the words. Read the instructions and explain the task. Students write the missing letters. Allow students some time to complete the task. Go around the classroom, giving help where necessary. Then, students point to and say the words. Check students' answers.

2 egg                      4 hen                      6 jug  
3 fish                      5 iguana

## ENDING THE LESSON

(An activity to revise the alphabet.)

### Before going into class

Photocopy the word cards: *apple, bed, cat, dog, egg, fish, glass, hen, iguana, jug*.

Write the letters *A-J* on the board. Hand out the photocopies. Ask the students to come to the board and stick their word card under the correct letter. Ask the rest of the class for verification.

**Note:** For further practice on the alphabet, you can hand out the photocopies of the corresponding *Alphabet Worksheets*.

## Kk-Ll

### Objectives

introducing the alphabet (Kk-Ll)

### Vocabulary

*kitten, lion*

### Extra Materials

- *My Alphabet* poster;
- photocopies of the word cards *apple, bed, cat, dog, egg, fish, glass, hen, iguana, jug, kitten, lion*;
- photocopies of the *Kk-Ll Alphabet Worksheet*.

## PRESENTATION & PRACTICE

(Activities to present the letters K-L.)

## 1 Listen and repeat. Then, colour. (TRACK 85)



POSTER

**Students' books closed.** Put up *My Alphabet* poster on the board. Revise letters A-J and the corresponding words. Then, point to the letters K, L and say the appropriate sounds. The students repeat chorally and individually. Point to the pictures and say the words. The students repeat chorally and individually.

**Students' books open.** Play the recording. The students listen to the letter sounds and the words and repeat chorally and individually. Individual pupils read the letters and the words. Then, students colour in the letters in the pictures.

## 2 Write the letters.

(Activities to practise writing the letters of the alphabet.)

Refer the students to the letters in Ex.2. Hold up your book and demonstrate how to use the arrows as guides to write each letter. Explain that they have to copy each letter twice, upper and lower case. Allow students some time to complete the task. Go around the classroom, giving help where necessary.

## 3 Listen and circle. (TRACK 86)

Read the instructions and explain the task. Play the recording. Students circle the letters. Allow students some time to complete the task. Go around the classroom, giving help where necessary. Check students' answers.

### TAPESCRIPT

1 D            3 G            5 A  
2 F            4 K            6 I

## 4 Look at the pictures and put a tick (✓) or a cross (X).

Read the instructions and explain the task. Students look at the pictures and put a tick or a cross accordingly. Allow students some time to complete the task. Go around the classroom, giving help where necessary. Check students' answers.

3 ✓            6 X  
4 ✓            7 ✓  
5 X            8 X

## ENDING THE LESSON

(An activity to revise the alphabet.)

### Before going into class

Photocopy the word cards: *apple, bed, cat, dog, egg, fish, glass, hen, iguana, jug, kitten, lion.*

Write the letters A-L on the board. Hand out the photocopies. Ask the students to come to the board and stick their word card under the correct letter. Ask the rest of the class for verification.

**Note:** For further practice on the alphabet, you can hand out the photocopies of the corresponding *Alphabet Worksheet*.

### Mm-Nn

#### Objectives

introducing the alphabet (Mm-Nn)

#### Vocabulary

*milk, nest*

#### Extra Materials

- *My Alphabet* poster;
- photocopies of the word cards *apple, bed, cat, dog, egg, fish, glass, hen, iguana, jug, kitten, lion, milk, nest*;
- photocopies of the *Mm-Nn Alphabet Worksheet*.

## PRESENTATION & PRACTICE

(Activities to present the letters M-N.)

## 1 Listen and repeat. Then, colour. (TRACK 87)



POSTER

**Students' books closed.** Put up *My Alphabet* poster on the board. Revise letters A-K and the corresponding words. Then, point to the letters M, N and say the appropriate sounds. The students repeat chorally and individually. Point to the pictures and say the words. The students repeat chorally and individually.

**Students' books open.** Play the recording. The students listen to the letter sounds and the words and repeat chorally and individually. Individual pupils read the letters and the words. Then, students colour in the letters in the pictures.

# My Alphabet

## ★ 2 Write the letters.

(Activities to practise writing the letters of the alphabet.)

Refer the students to the letters in Ex.2. Hold up your book and demonstrate how to use the arrows as guides to write each letter. Explain that they have to copy each letter twice, upper and lower case. Allow students some time to complete the task. Go around the classroom, giving help where necessary.

## ★ 3 Listen and join the letters. (TRACK 88)

Read the instructions and explain the task. Students listen and join the letters. Allow students some time to complete the task. Go around the classroom, giving help where necessary. Check students' answers.

### TAPESCRIPT

B, A, N, M, L, K, J, I, H, G, F, E, D, C

## ★ 4 Look and complete the words.

Refer the students to the picture. Elicit the words. Read the instructions and explain the task. Allow students some time to complete the task. Go around the classroom, giving help where necessary. Check students' answers.

2 BED bed	5 FISH fish	8 NEST nest
3 CAT cat	6 IGUANA iguana	
4 DUCK duck	7 MILK milk	

## ENDING THE LESSON

(An activity to revise the alphabet.)

### Before going into class

Photocopy the word cards *apple, bed, cat, dog, egg, fish, glass, hen, iguana, jug, kitten, lion, milk, nest.*

Write the letters A-N on the board. Hand out the photocopies. Ask the students to come to the board and stick their word under the correct letter. Ask the rest of the class for verification.

**Note:** For further practice on the alphabet, you can hand out the photocopies of the corresponding *Alphabet Worksheets*.

### Oo-Pp

#### Objectives

introducing the alphabet (Oo-Pp)

#### Vocabulary

*orange, pen*

#### Extra Materials

- *My Alphabet* poster;
- photocopies of the word cards *apple, bed, cat, dog, egg, fish, glass, hen, iguana, jug, kitten, lion, milk, nest, orange, pen;*
- photocopies of the *Oo-Pp Alphabet Worksheets*.

## PRESENTATION & PRACTICE

(Activities to present the letters O-P)

## ★ 1 Listen and repeat. Then, colour. (TRACK 89)



POSTER

**Students' books closed.** Put up *My Alphabet* poster on the board. Revise letters A-N and the corresponding words. Then, point to the letters O, P and say the appropriate sounds. The students repeat chorally and individually. Point to the pictures and say the words. The students repeat chorally and individually.

**Students' books open.** Play the recording. The students listen to the letter sounds and the words and repeat chorally and individually. Individual pupils read the letters and the words. Then, students colour in the letters in the pictures.

## ★ 2 Write the letters.

(Activities to practise writing the letters of the alphabet.)

Refer the students to the letters in Ex.2. Hold up your book and demonstrate how to use the arrows as guides to write each letter. Explain that they have to copy each letter twice, upper and lower case. Allow students some time to complete the task. Go around the classroom, giving help where necessary.

## ★ 3 Listen and write the beginning letter. Then, use the code and colour the pictures. (TRACK 90)

Read the instructions and explain the task. Play the recording. Allow students some time to complete the task. Students listen and write the beginning letter. Then they use the code and colour in the pictures. Go

around the classroom, giving help where necessary. Check students' answers.

**pen:** green  
**orange:** orange  
**pizza:** green  
**octopus:** orange

## ★ 4 Look, read and match.

Read the instructions and explain the task. Students match the pictures to the words. Allow students some time to complete the task. Go around the classroom, giving help where necessary. Check students' answers.

## ENDING THE LESSON

(An activity to revise the alphabet.)

### Before going into class

Photocopy the word cards *apple, bed, cat, dog, egg, fish, glass, hen, iguana, jug, kitten, lion, milk, nest, orange, pen.*

Write the letters A-P on the board. Hand out the photocopies. Ask the students to come to the board and stick their word card under the correct letter. Ask the rest of the class for verification.

**Note:** For further practice on the alphabet, you can hand out the photocopies of the corresponding *Alphabet Worksheets*.

### Qq-Rr

#### Objectives

introducing the alphabet (Qq-Rr)

#### Vocabulary

*queen, rabbit*

#### Extra Materials

- *My Alphabet* poster;
- photocopies of the word cards *apple, bed, cat, dog, egg, fish, glass, hen, iguana, jug, kitten, lion, milk, nest, orange, pen, queen, rabbit;*
- photocopies of the *Qq-Rr Alphabet Worksheets*.

## PRESENTATION & PRACTICE

(Activities to present the letters Q-R)

## ★ 1 Listen and repeat. Then, colour. (TRACK 91)



POSTER

**Students' books closed.** Put up *My Alphabet* poster on the board. Revise letters A-P and the corresponding words. Then, point to the letters Q, R and say the appropriate sounds. The students repeat chorally and individually. Point to the pictures and say the words. The students repeat chorally and individually.

**Students' books open.** Play the recording. The students listen to the letter sounds and the words and repeat chorally and individually. Individual pupils read the letters and the words. Then, students colour in the letters in the pictures.

## ★ 2 Write the letters.

(Activities to practise writing the letters of the alphabet.)

Refer the students to the letters in Ex.2. Hold up your book and demonstrate how to use the arrows as guides to write each letter. Explain that they have to copy each letter twice, upper and lower case. Allow students some time to complete the task. Go around the classroom, giving help where necessary.

## ★ 3 What's next? Write.

Read the instructions and explain the task. Students look at the patterns and guess the next letter. Allow students some time to complete the task. Go around the classroom, giving help where necessary. Check students' answers.

q Q R r

## ★ 4 Look, read and match.

Read the instructions and explain the task. Students match the pictures to the words. Allow students some time to complete the task. Go around the classroom, giving help where necessary. Check students' answers.

## ENDING THE LESSON

(An activity to revise the alphabet.)

### Before going into class

Photocopy the word cards *apple, bed, cat, dog, egg, fish, glass, hen, iguana, jug, kitten, lion, milk, nest, orange, pen, queen, rabbit.*

# My Alphabet

Write the letters A-R on the board. Hand out the photocopies. Ask the students to come to the board and stick their word card under the correct letter. Ask the rest of the class for verification.

**Note:** For further practice on the alphabet, you can hand out the photocopies of the corresponding *Alphabet Worksheets*.

## Ss-Tt

### Objectives

introducing the alphabet (Ss-Tt)

### Vocabulary

*snake, tree*

### Extra Materials

- *My Alphabet* poster;
- photocopies of the word cards *apple, bed, cat, dog, egg, fish, glass, hen, iguana, jug, kitten, lion, milk, nest, orange, pen, queen, rabbit, snake, tree*;
- photocopies of the *Ss-Tt Alphabet Worksheet*.

## PRESENTATION & PRACTICE

(Activities to present the letters S-T)

### 1 Listen and repeat. Then, colour. (TRACK 92)



#### POSTER

**Students' books closed.** Put up *My Alphabet* poster on the board. Revise letters A-R and the corresponding words. Then, point to the letters S, T and say the appropriate sounds. The students repeat chorally and individually. Point to the pictures and say the words. The students repeat chorally and individually.

**Students' books open.** Play the recording. The students listen to the letter sounds and the words and repeat chorally and individually. Individual pupils read the letters and the words. Then, students colour in the letters in the pictures.

### 2 Write the letters.

(Activities to practise writing the letters of the alphabet.)

Refer the students to the letters in Ex.2. Hold up your book and demonstrate how to use the arrows as guides to write each letter. Explain that they have to copy each letter twice, upper and lower case. Allow

students some time to complete the task. Go around the classroom, giving help where necessary.

### 3 Find and circle the words. Then, match them to the pictures.

Read the instructions and explain the task. Students find and circle the words. Then, they match the words to the pictures. Allow students some time to complete the task. Go around the classroom, giving help where necessary. Check students' answers.

jug, kitten, queen, rabbit, snake, lion, milk, nest, orange, pen, tree

### 4 Look at the pictures and complete the crossword puzzle.

Read the instructions and explain the task. Students look at the pictures and complete the crossword puzzle. Allow students some time to complete the task. Go around the classroom, giving help where necessary. Check students' answers.

- |          |          |       |
|----------|----------|-------|
| 1 rabbit | 4 nest   | 7 egg |
| 2 pen    | 5 tree   |       |
| 3 apple  | 6 kitten |       |

## ENDING THE LESSON

(An activity to revise the alphabet.)

### Before going into class

Photocopy the word cards *apple, bed, cat, dog, egg, fish, glass, hen, iguana, jug, kitten, lion, milk, nest, orange, pen, queen, rabbit, snake, tree*.

Write the letters A-T on the board. Hand out the photocopies. Ask the students to come to the board and stick their word card under the correct letter. Ask the rest of the class for verification.

**Note:** For further practice on the alphabet, you can hand out the photocopies of the corresponding *Alphabet Worksheets*.



## Uu-Vv

### Objectives

introducing the alphabet (Uu-Vv)

### Vocabulary

*umbrella, van*

### Extra Materials

- *My Alphabet* poster;
- photocopies of the word cards *apple, bed, cat, dog, egg, fish, glass, hen, iguana, jug, kitten, lion, milk, nest, orange, pen, queen, rabbit, snake, tree, umbrella, van*;
- photocopies of the *Uu-Vv Alphabet Worksheets*.

- |          |         |
|----------|---------|
| 1 bed    | 5 lion  |
| 2 duck   | 6 nest  |
| 3 hen    | 7 snake |
| 4 iguana | 8 van   |

### 4 Trace the words. Then, match them to the pictures.

Read the instructions and explain the task. Students trace the words and match them to the pictures. Allow students some time to complete the task. Go around the classroom, giving help where necessary. Check students' answers.

## ENDING THE LESSON

(An activity to revise the alphabet.)

### Before going into class

Photocopy the word cards *apple, bed, cat, dog, egg, fish, glass, hen, iguana, jug, kitten, lion, milk, nest, orange, pen, queen, rabbit, snake, tree, umbrella, van*.

Write the letters A-V on the board. Hand out the photocopies. Ask the students to come to the board and stick their word card under the correct letter. Ask the rest of the class for verification.

**Note:** For further practice on the alphabet, you can hand out the photocopies of the corresponding *Alphabet Worksheets*.

## Ww-Xx

### Objectives

introducing the alphabet (Ww-Xx)

### Vocabulary

*window, fox*

### Extra Materials

- *My Alphabet* poster;
- photocopies of the word cards *apple, bed, cat, dog, egg, fish, glass, hen, iguana, jug, kitten, lion, milk, nest, orange, pen, queen, rabbit, snake, tree, umbrella, van, window, fox*;
- photocopies of the *Ww-Xx Alphabet Worksheets*.

## PRESENTATION & PRACTICE

(Activities to present the letters U-V)

### 1 Listen and repeat. Then, colour. (TRACK 93)



POSTER

**Students' books closed.** Put up *My Alphabet* poster on the board. Revise letters A-T and the corresponding words. Then, point to the letters U, V and say the appropriate sounds. The students repeat chorally and individually. Point to the pictures and say the words. The students repeat chorally and individually.

**Students' books open.** Play the recording. The students listen to the letter sounds and the words and repeat chorally and individually. Individual pupils read the letters and the words. Then, students colour in the letters in the pictures.

### 2 Write the letters.

(Activities to practise writing the letters of the alphabet.)

Refer the students to the letters in Ex.2. Hold up your book and demonstrate how to use the arrows as guides to write each letter. Explain that they have to copy each letter twice, upper and lower case. Allow students some time to complete the task. Go around the classroom, giving help where necessary.

### 3 Look, read and circle the right word.

Read the instructions and explain the task. Students look at the pictures and circle the correct words. Allow students some time to complete the task. Go around the classroom, giving help where necessary. Check students' answers.

## PRESENTATION & PRACTICE

(Activities to present the letters W-X)

### 1 Listen and repeat. Then, colour. (TRACK 94)



POSTER

**Students' books closed.** Put up *My Alphabet* poster on the board. Revise letters A-V and the corresponding words. Then, point to the letters W, X and say the appropriate sounds. The students repeat chorally and individually. Point to the pictures and say the words. The students repeat chorally and individually.

**Students' books open.** Play the recording. The students listen to the letter sounds and the words and repeat chorally and individually. Individual pupils read the letters and the words. Then, students colour in the letters in the pictures.

### 2 Write the letters.

(Activities to practise writing the letters of the alphabet.)

Refer the students to the letters in Ex.2. Hold up your book and demonstrate how to use the arrows as guides to write each letter. Explain that they have to copy each letter twice, upper and lower case. Allow students some time to complete the task. Go around the classroom, giving help where necessary.

### 3 Write the words in upper case.

Read the instructions and explain the task. Students write the words in upper case letters. Allow students some time to complete the task. Go around the classroom, giving help where necessary. Check students' answers.

- |         |           |           |
|---------|-----------|-----------|
| 2 CAT   | 7 KITTEN  | 12 SNAKE  |
| 3 DUCK  | 8 LION    | 13 WINDOW |
| 4 FISH  | 9 NEST    | 14 FOX    |
| 5 GLASS | 10 ORANGE |           |
| 6 JUG   | 11 QUEEN  |           |

### 4 Find and circle 14 words. Then, match them to the pictures.

Read the instructions and explain the task. Students circle the words and match them to the pictures. Allow students some time to complete the task. Go around the classroom, providing help where necessary. Check students' answers.

FOX, BED, IGUANA, EGG, FISH, HEN, JUG, KITTEN, LION, MILK, NEST, PEN, TREE

## ENDING THE LESSON

(An activity to revise the alphabet.)

### Before going into class

Photocopy the word cards *apple, bed, cat, dog, egg, fish, glass, hen, iguana, jug, kitten, lion, milk, nest, orange, pen, queen, rabbit, snake, tree, umbrella, van, window, fox.*

Write the letters A-X on the board. Hand out the photocopies. Ask the students to come to the board and stick their word card under the correct letter. Ask the rest of the class for verification.

**Note:** For further practice on the alphabet, you can hand out the photocopies of the corresponding *Alphabet Worksheets*.

### Yy-Zz

#### Objectives

introducing the alphabet (Yy-Zz)

#### Vocabulary

yo-yo, zebra

#### Extra Materials

- *My Alphabet* poster;
- photocopies of the word cards *apple, bed, cat, dog, egg, fish, glass, hen, iguana, jug, kitten, lion, milk, nest, orange, pen, queen, rabbit, snake, tree, umbrella, van, window, fox, yo-yo, zebra*;
- photocopies of the *Yy-Zz Alphabet Worksheets*.

## PRESENTATION & PRACTICE

(Activities to present the letters Y-Z)

### 1 Listen and repeat. Then, colour. (TRACK 95)



POSTER

**Students' books closed.** Put up *My Alphabet* poster on the board. Revise letters A-X and the corresponding words. Then, point to the letters Y, Z and say the appropriate sounds. The students repeat chorally and individually. Point to the pictures and say the words. The students repeat chorally and individually.

**Students' books open.** Play the recording. The students

listen to the letter sounds and the words and repeat chorally and individually. Individual pupils read the letters and the words. Then, students colour in the letters in the pictures.

## ★ 2 Write the letters.

(Activities to practise writing the letters of the alphabet.)

Refer the students to the letters in Ex. 2. Hold up your book and demonstrate how to use the arrows as guides to write each letter. Explain that they have to copy each letter twice, upper and lower case. Allow students some time to complete the task. Go around the classroom, giving help where necessary.

## ★ 3 Correct the mistakes.

Read the instructions and explain the task. Students read the words and correct the mistakes. Allow students some time to complete the task. Go around the classroom, giving help where necessary. Check students' answers.

- |        |         |         |
|--------|---------|---------|
| 2 cat  | 5 milk  | 8 zebra |
| 3 duck | 6 snake |         |
| 4 fish | 7 van   |         |

## ★ 4 Read and colour.

Read the instructions and explain the task. Students read and colour in the pictures accordingly. Allow students some time to complete the task. Go around the classroom, providing help where necessary. Check students' answers.

## ENDING THE LESSON

(An activity to revise the alphabet.)

### Before going into class

Photocopy the word cards *apple, bed, cat, dog, egg, fish, glass, hen, iguana, jug, kitten, lion, milk, nest, orange, pen, queen, rabbit, snake, tree, umbrella, van, window, fox, yo-yo, zebra.*

Write the letters A-Z on the board. Hand out the photocopies. Ask the students to come to the board and stick their word card under the correct letter. Ask the rest of the class for verification.

**Note:** For further practice on the alphabet, you can hand out the photocopies of the corresponding *Alphabet Worksheets*.

### Aa-Zz

#### Objectives

alphabet revision

#### Vocabulary

Aa-Zz

#### Extra Materials

- *My Alphabet* poster;
- slips of paper with the lower case *Alphabet Letters*.

## PRESENTATION & PRACTICE

(Activities to revise the alphabet)

### ★ 1 Listen and repeat. (TRACK 96)



#### POSTER

**Students' books closed.** Put up *My Alphabet* poster on the board. Revise letters A-Z and the corresponding words. Then, point to all the letters and say the appropriate sounds. The students repeat chorally and individually. Point to the pictures and say the words. The students repeat chorally and individually.

**Students' books open.** Play the recording. The students listen to the letter sounds, and repeat chorally and individually. Individual students read the letters out loud.

### ★ 2 Find and join.

Read the instructions and explain the task. Students join the letters to make words and match them to their corresponding words below. Allow students some time to complete the task. Go around the classroom, providing help where necessary. Check students' answers.

### ★ 3 Circle the letters. Then, write the word.

Read the instructions and explain the task. Students circle the letters. Then they write the words. Allow students some time to complete the task. Go around the classroom, providing help where necessary. Check students' answers.

- |          |          |
|----------|----------|
| 1 window | 3 kitten |
| 2 rabbit | 4 orange |

### ★ 4 Let's sing! (TRACK 97)

Read the instructions and explain the task. Students listen and point to the letters. Play the recording again

# My Alphabet

pausing at certain letters and elicit the letters from the students.

## ENDING THE LESSON

*(An activity to revise the alphabet.)*

### Before going into class

Bring in slips of paper with the lower case letters of the alphabet, one letter on each slip of paper.

Distribute the slips of papers with the alphabet letters. Write the alphabet letters on the board. The student that has the corresponding lower case letter must come to the board and stick his/her paper next to the upper case letter.

Evaluation plays an integral part in the learning process, and it is more efficient when based on the systematic observation of the students throughout the course. It provides valuable information that reflects their progress in the acquisition of receptive and productive skills as well as their attitude towards their own learning experience. It also allows teachers to reflect on the validity of their teaching practices and the types of material being used.

The process is basically divided into three parts: *initial evaluation* at the beginning of the course, *formative evaluation* which is done on a daily basis, and *cumulative evaluation* upon finishing a module.

In **Starlight Starter** the evaluation activities are included in both the *Teacher's Book* and the *Student's Book*.

## Initial evaluation

This evaluation centres mainly on the students' reports from the previous school year, as the information should help the teacher find out about the strategies they are able to use.

## Formative evaluation

Any exercise a student does can be used for this type of evaluation. The results are then recorded on the student's *formative evaluation chart* (page 102).

Make as many photocopies as you need and complete the charts as indicated. Write the names of the activities you are going to evaluate (for example, the dialogues, language games, craft activities, and so on) and write the marks obtained with the help of the following code:

★★★★★ – the student recognises and produces the language

★★★ – the student recognises but does not produce the language correctly

★ – the student does not recognise the language

## Cumulative evaluation

The results of cumulative evaluation are recorded on the student's *cumulative evaluation chart* (page 103).

In the Student's Book the last page of the module is used for cumulative evaluation. However, in order to obtain reliable information, the formative evaluation marks, work done throughout the module participation and attitude should also be taken into account.

In order to complete the chart, write down the students' names and record the results using numbers or letters in the corresponding columns. The code for formative evaluation can also be used here.

## Evaluation chart for games and activities (formative evaluation)

Name of game/activity: .....

Aim of game/activity: .....

Module: ..... Lesson: ..... Course: .....

Student's name	Mark and comments
1	
2	
3	
4	
5	
6	
7	
8	
9	
10	
11	
12	
13	
14	
15	
16	
17	
18	
19	
20	
21	
22	
23	
24	
25	

Evaluation criteria: ★★★★★    ★★★    ★



## Evaluation chart for each module (cumulative evaluation)

**Module:** .....  
**Date:** .....  
**Course:** .....

Student's name

	1	2	3	4	5	6	7	8	9	10	11	12	13	14	15	16	17	18	19	20	21	22	23	24	25
<b>Aims:</b> The student is able to ...																									
1																									
2																									
3																									
4																									
5																									
6																									
7																									
8																									
9																									

Marking criteria: ★★★★★ ★★★★★★ ★★★★★★★★ ★★★★★★★★★★ ★★★★★★★★★★★★★★

**Attitudes:**

1																									
2																									
3																									

Marking criteria: ✓ Yes ✗ No | Improving

## Module 3

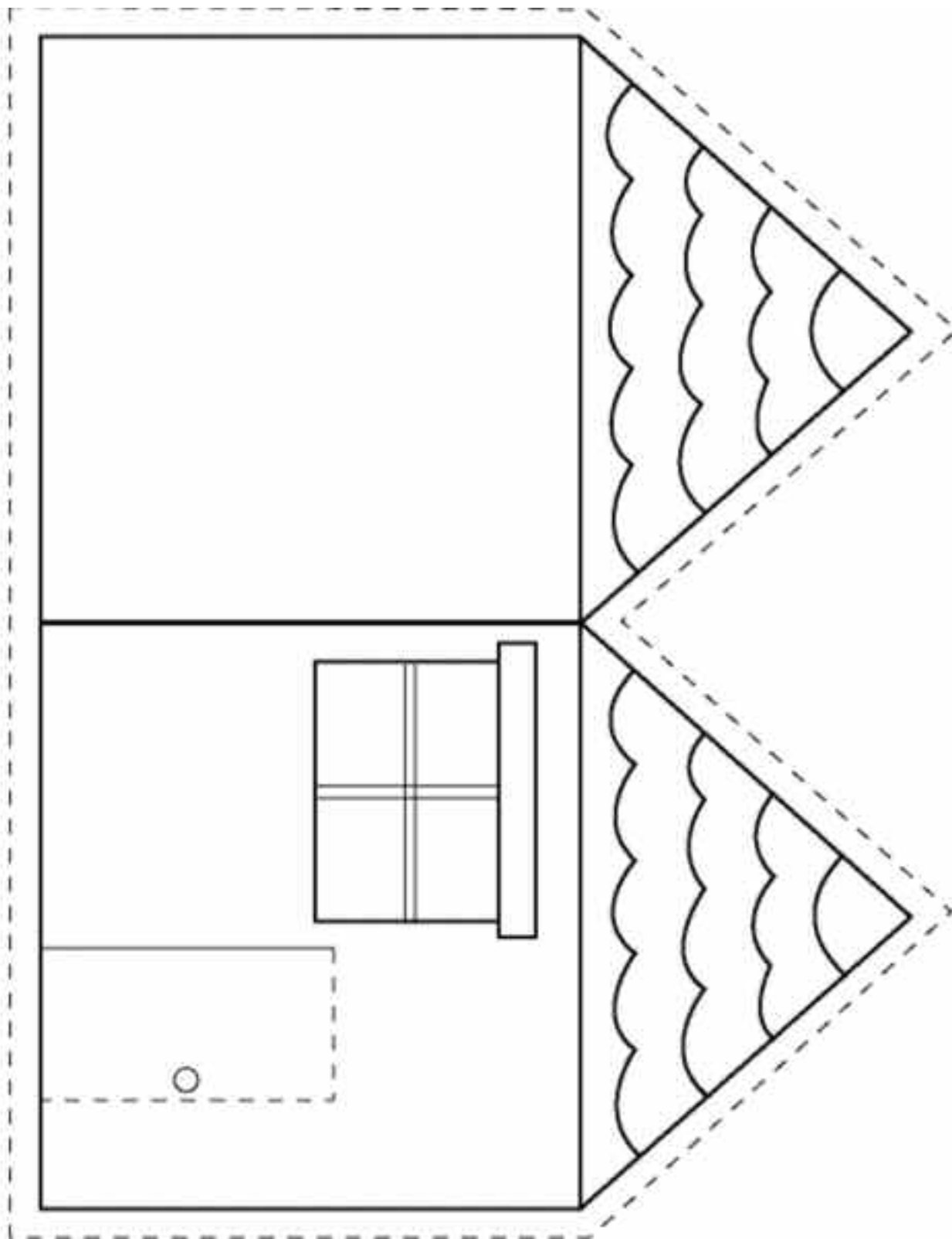

Module 4



## Module 4



Module 4



## Module 5

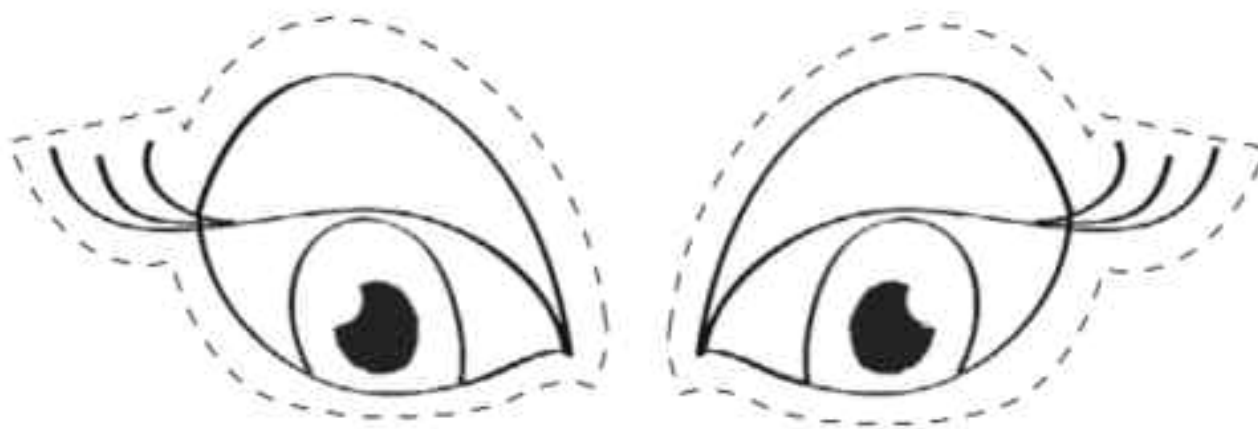
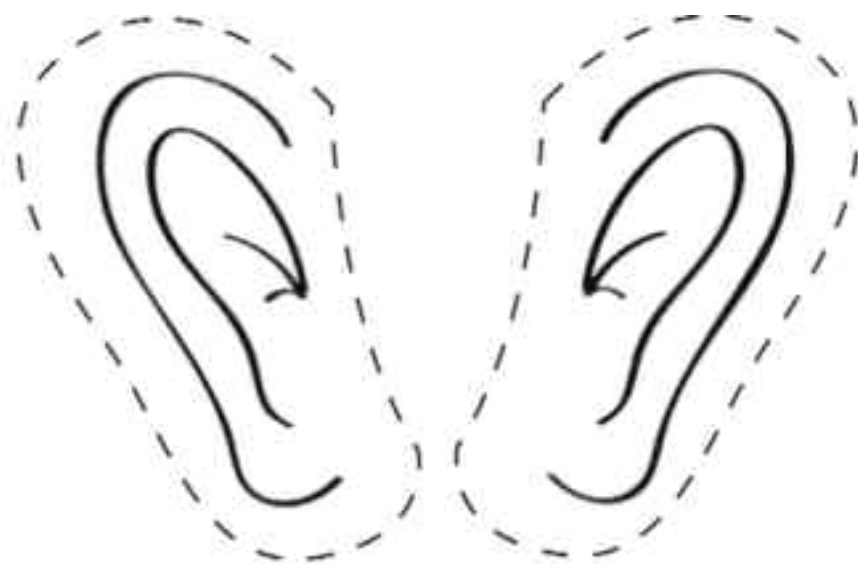



Module 5

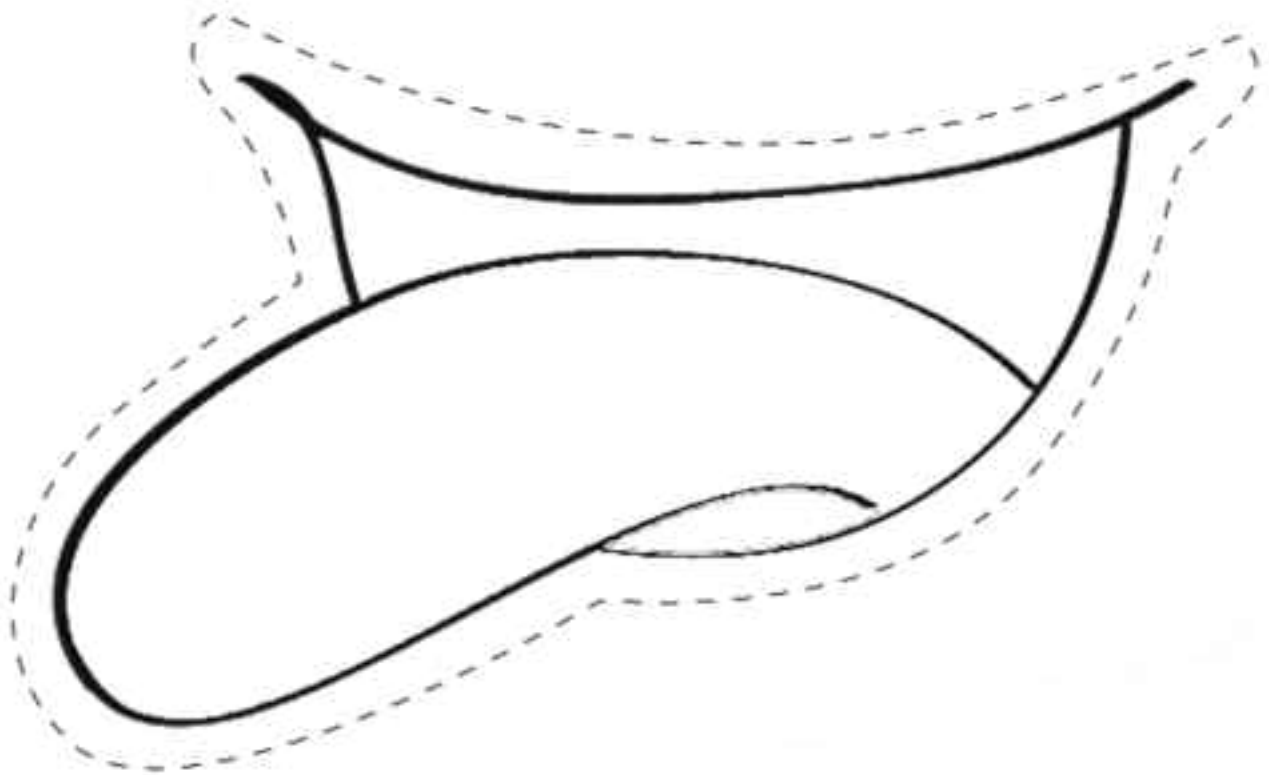

## Module 5

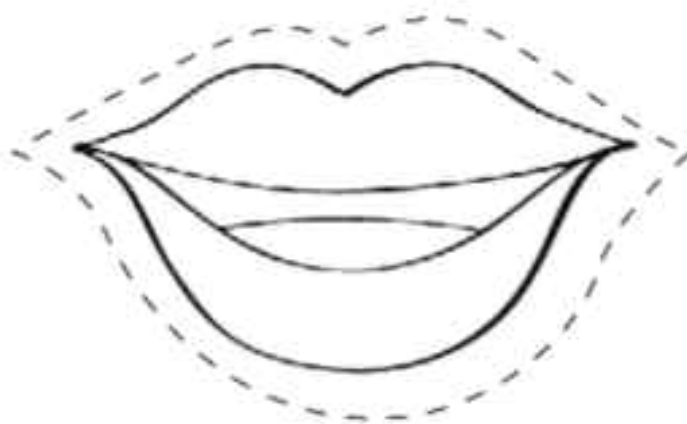

**Module 6**

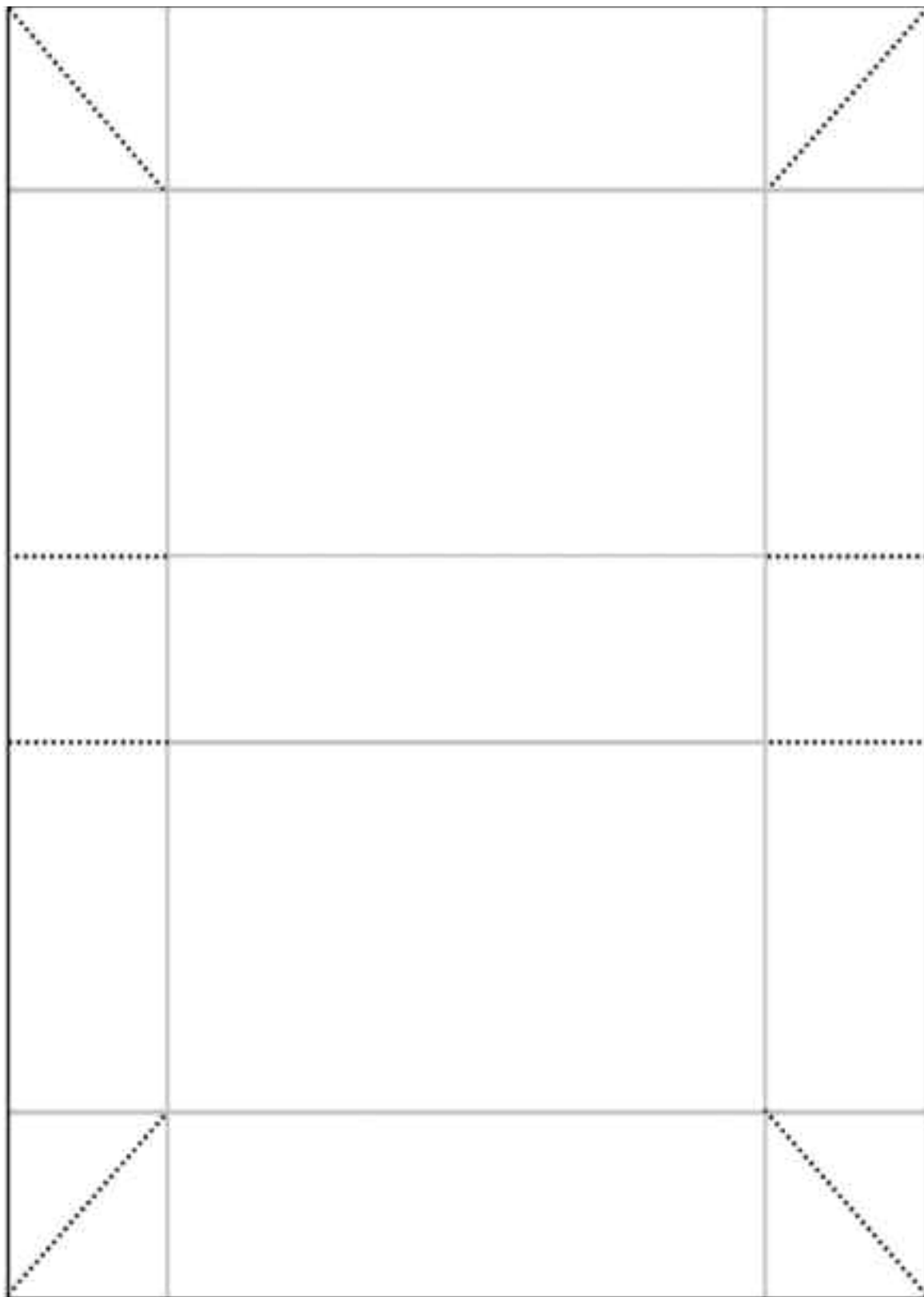

## Module 6

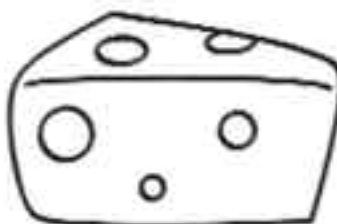
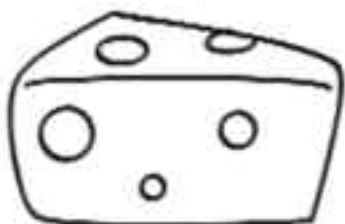
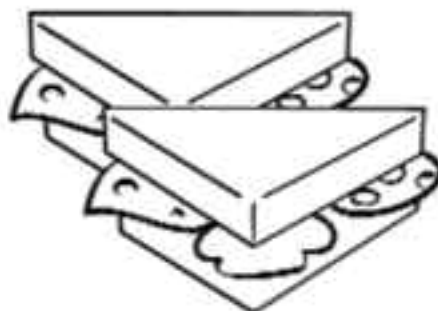
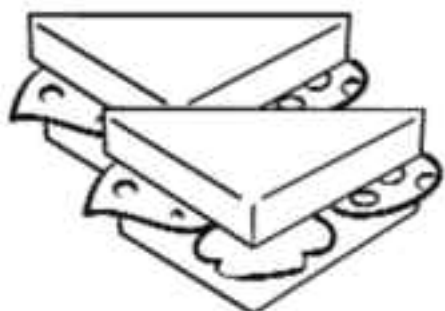

Module 6

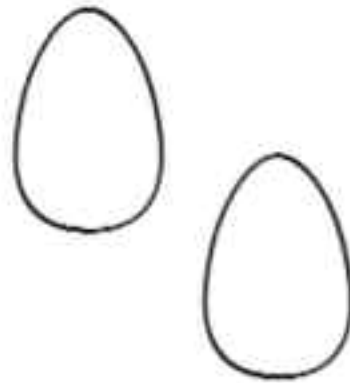
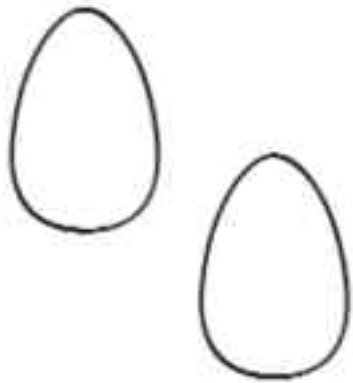

## Module 7





Module 7

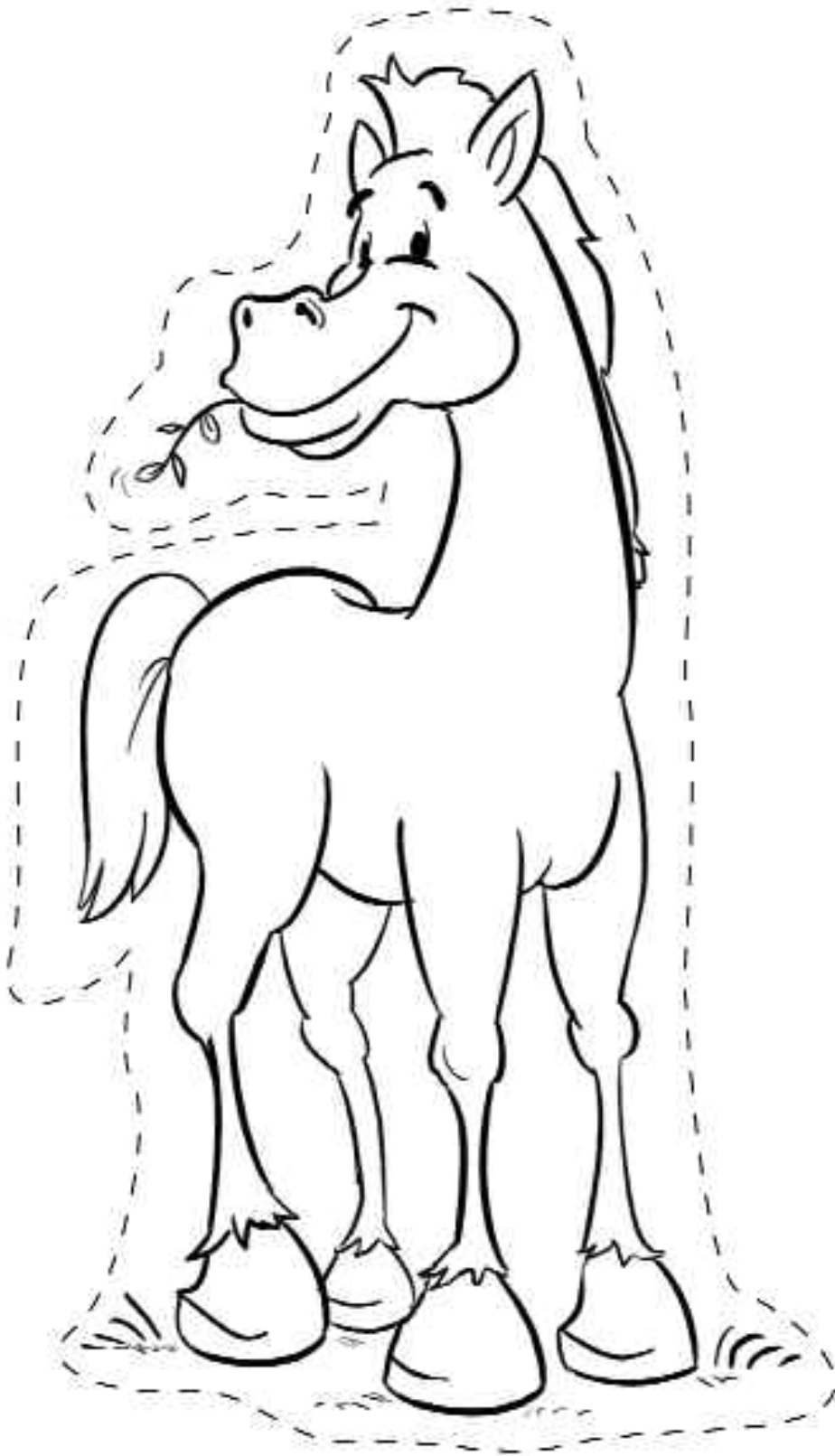

## Module 7



Module 7

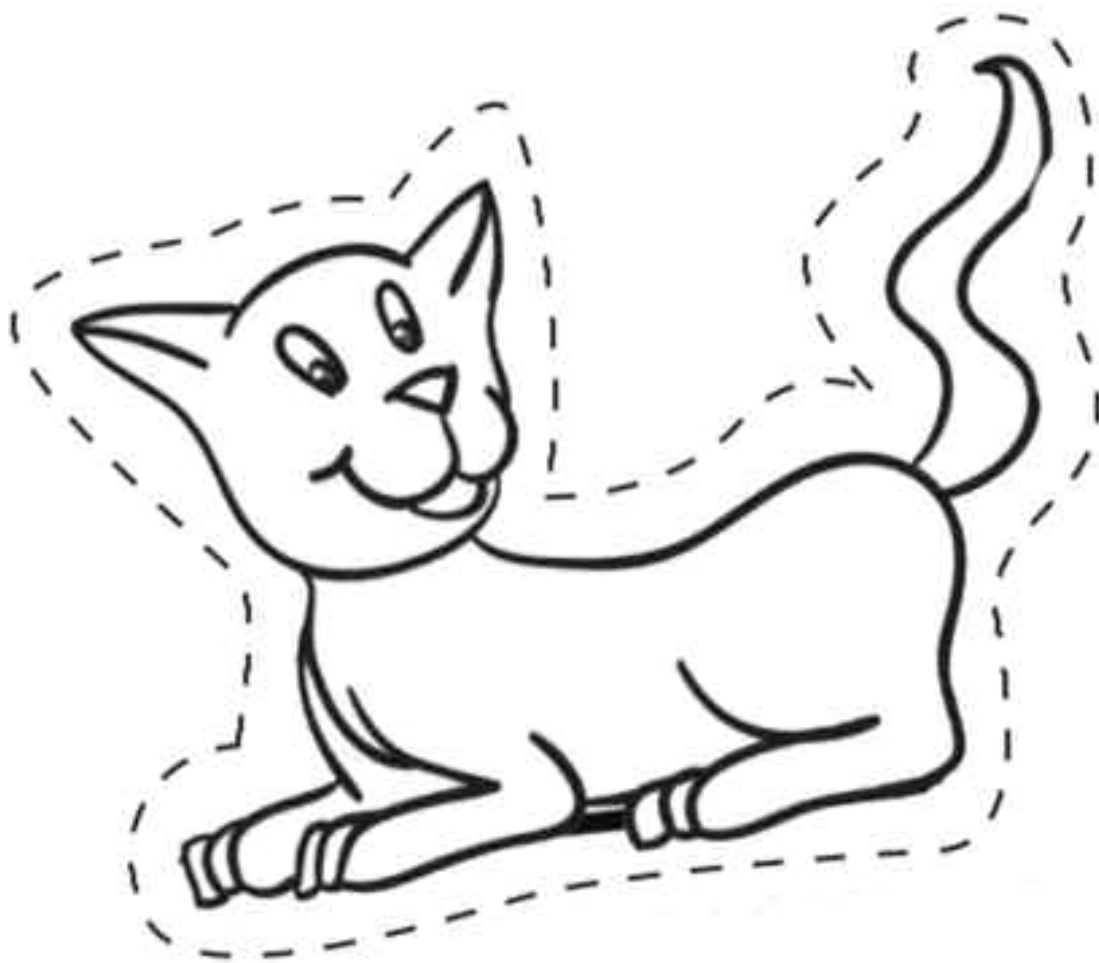

## Module 7

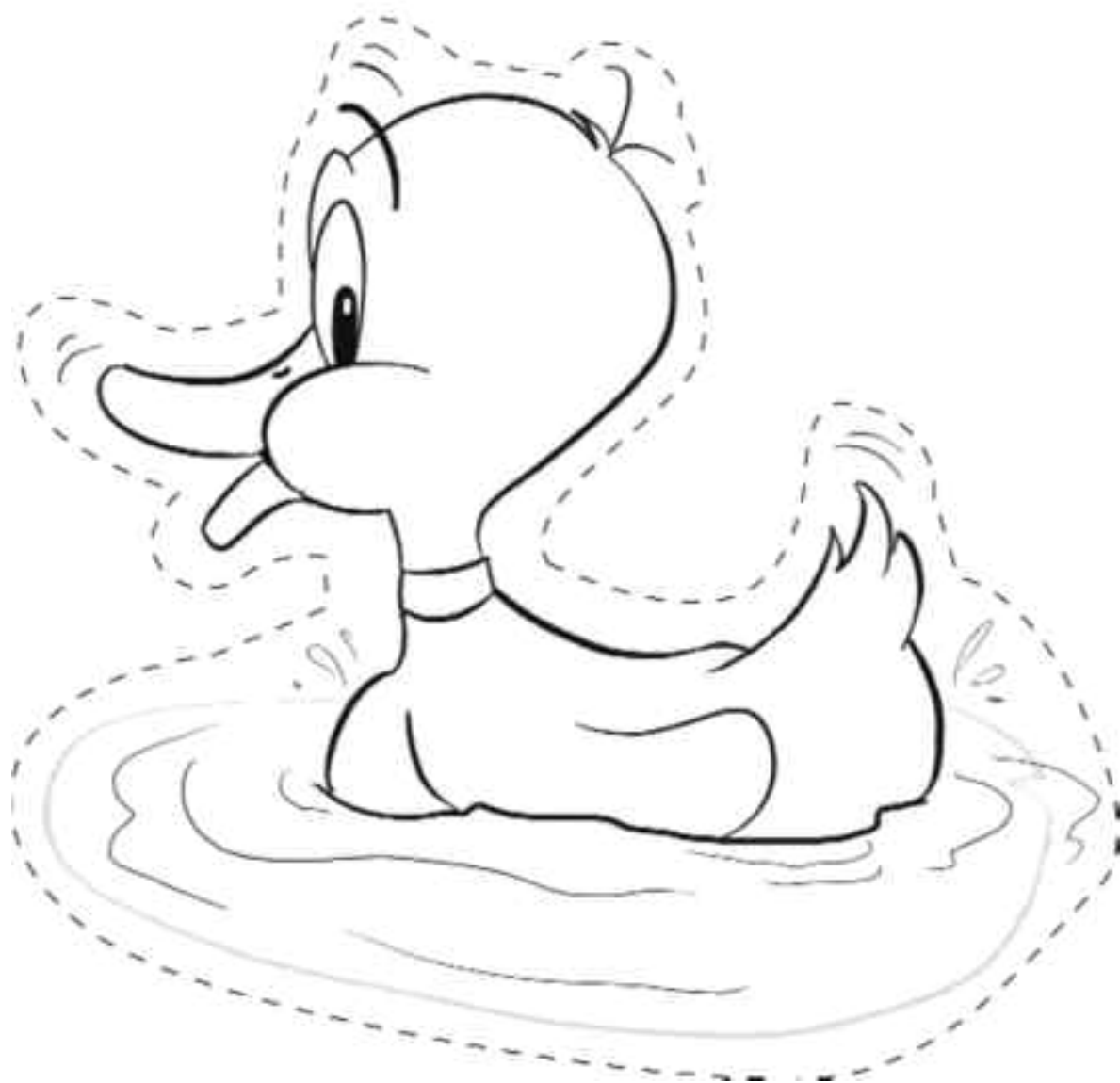

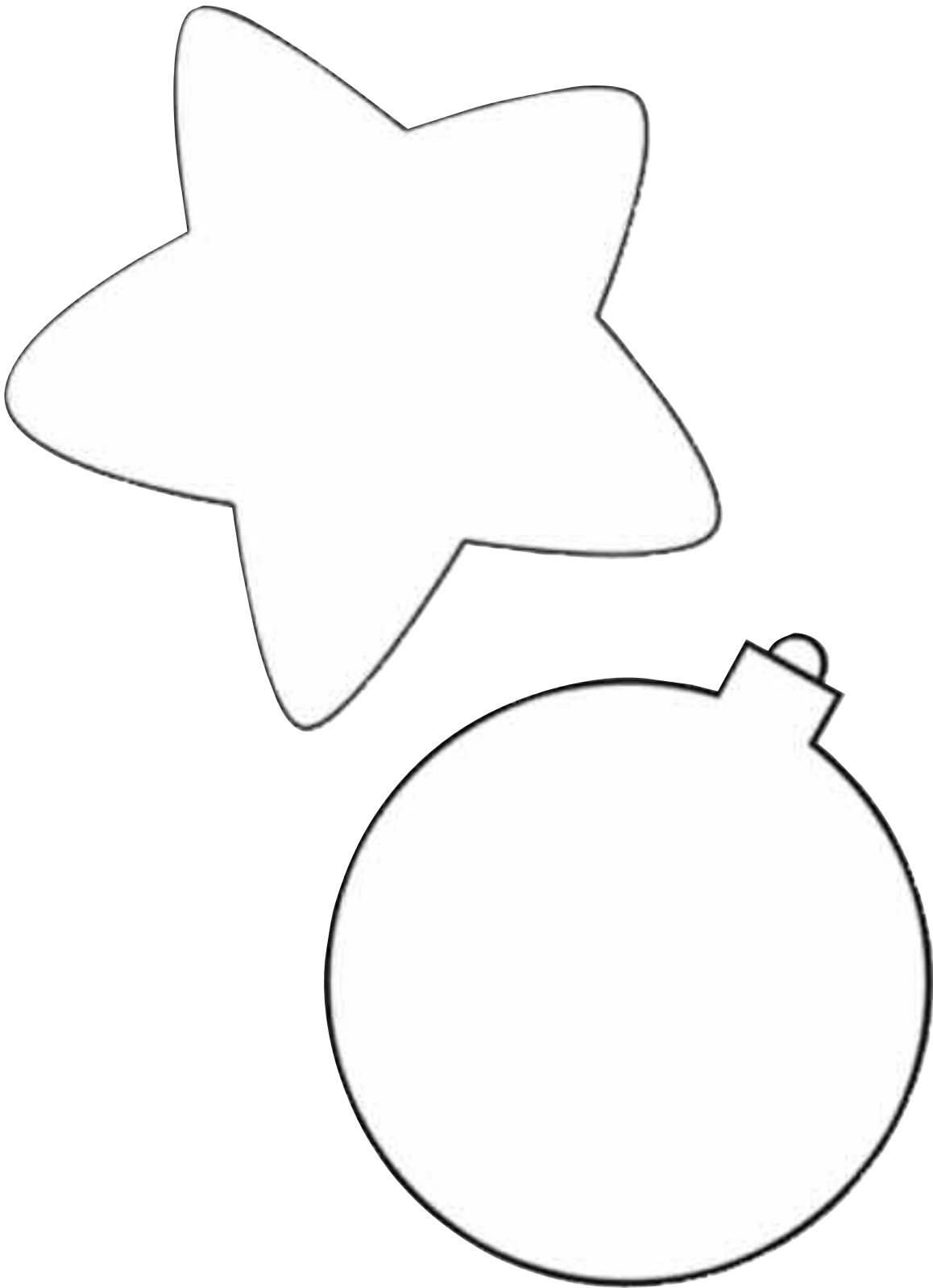

# Alphabet Picture-Word Cards

**A a**



**apple**

**B b**



**bed**

**C c**



**cat**

**D d**



**dog**

**E e**



**egg**



**F f**

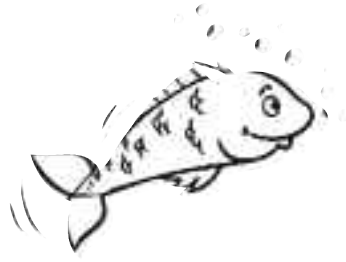

**fish**

**G g**



**glass**

**H h**



**hen**

**I i**



**iguana**

**J j**



**jug**

# Alphabet Picture-Word Cards

**K k**



**kitten**

**L l**



**lion**

**M m**



**milk**

**N n**



**nest**

**O o**

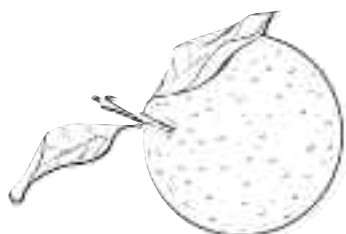

**orange**

**P p**



**pen**

**Q q**



**queen**

**R r**



**rabbit**

**S s**



**snake**

**T t**



**tree**

# Alphabet Picture-Word Cards

**U u**



**umbrella**

**V v**

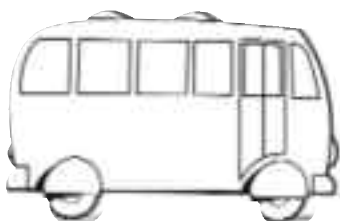

**van**

**W w**

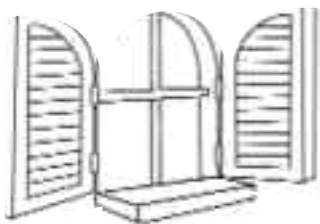

**window**

**X x**



**fox**

**Y y**



**yo-yo**

**Z z**



**zebra**



ant



apple

A a

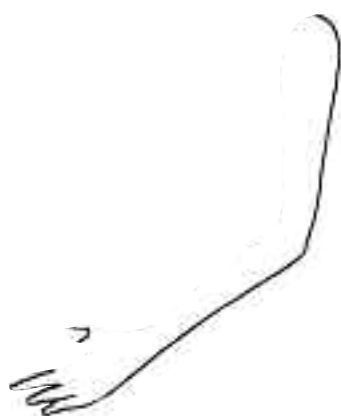

arm



book

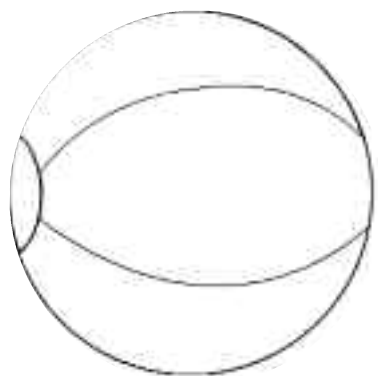

ball



pen

B b

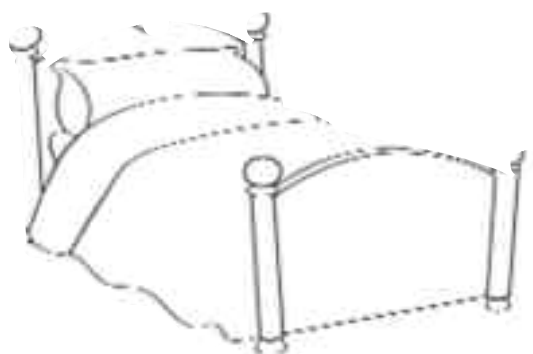

bed



bat





car

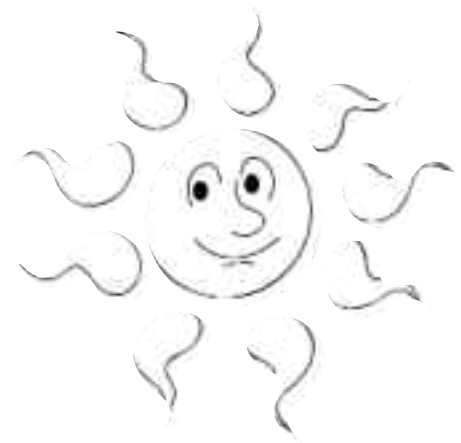

sun

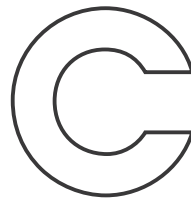
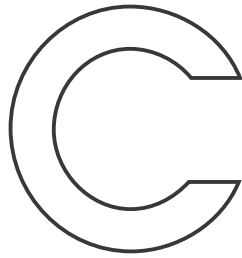

cat



cola



**dog**



**duck**

D

d



**doll**

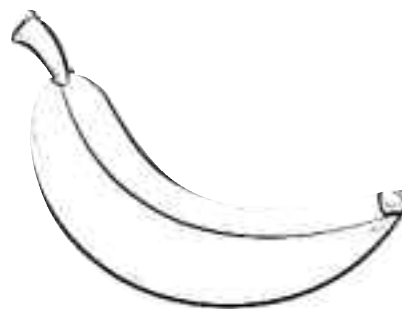

**banana**



ears



cow

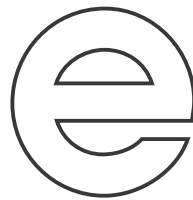
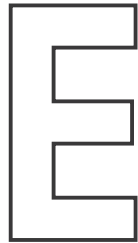

eyes

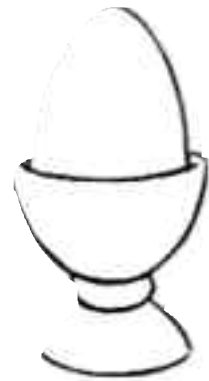

egg



teddy

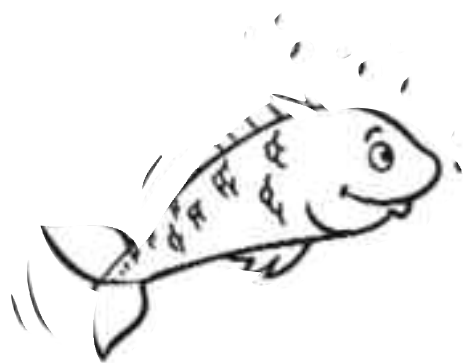

fish

F f

5

five

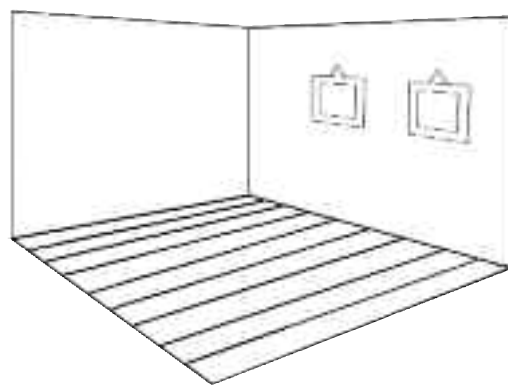

floor



glass

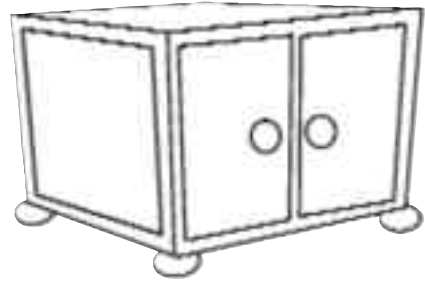

cupboard

G

g



girl



ghost



hat



horse

H h



hen

9

nine



Indian



igloo

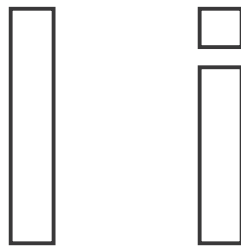

four



iguana





jacket



jug

J j

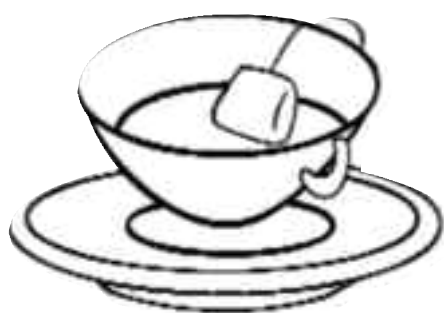

tea



jaguar

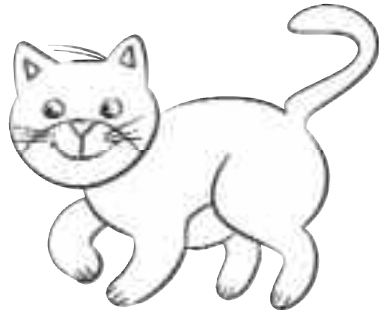

kitten



hen

K k



koala



kite



lion

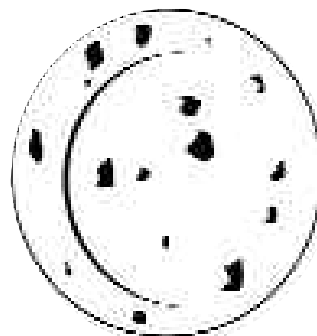

biscuit

L I

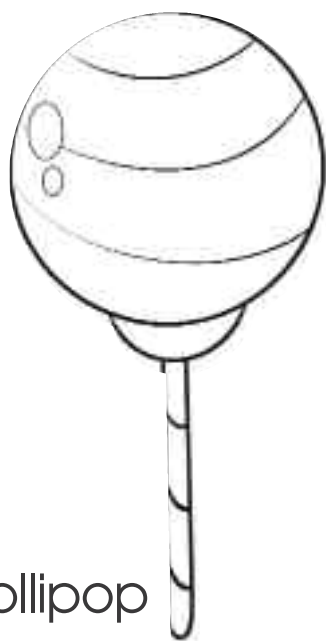

lollipop

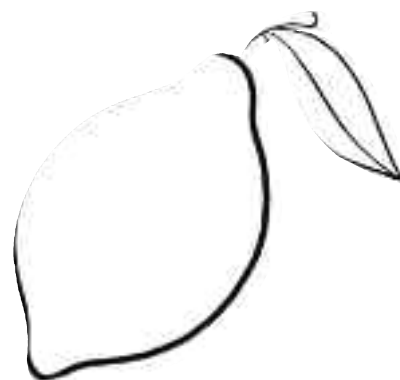

lemon



**milk**



**moon**

M

m



**mouse**

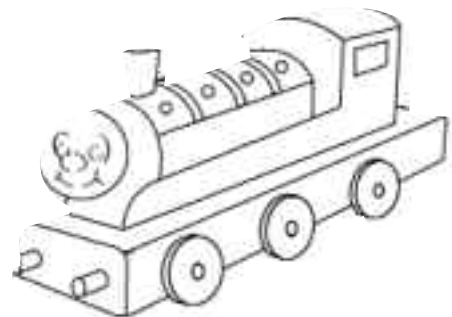

**train**



nut



nose

N n



mouth



nest



olive



octopus

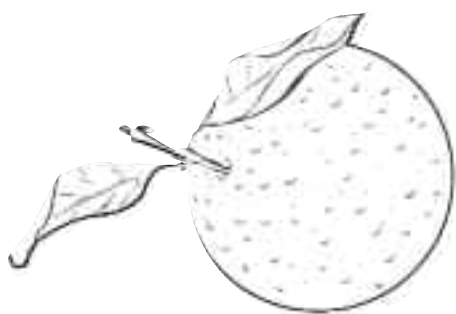
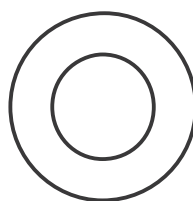
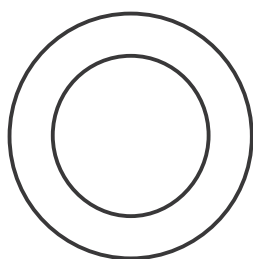

orange



climb



pen

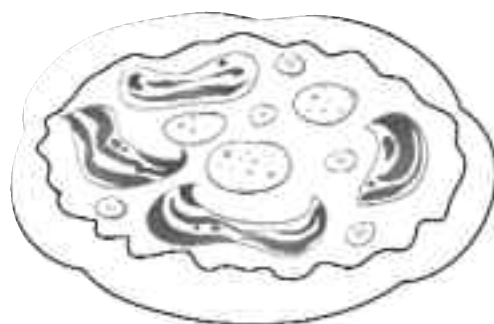

pizza

P p



plane



flower





queen

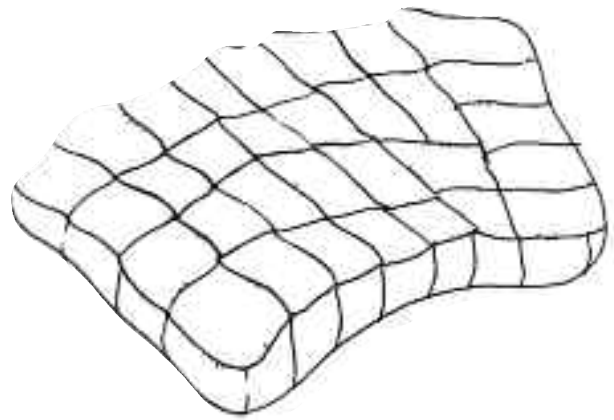

quilt

Q q



onion

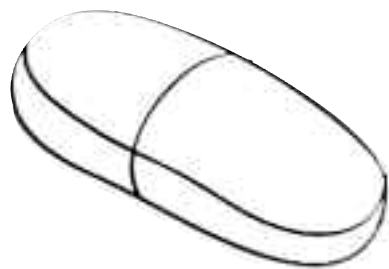

rubber



rabbit

R r

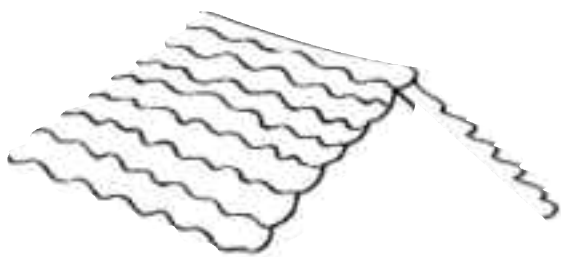

roof



house



snake

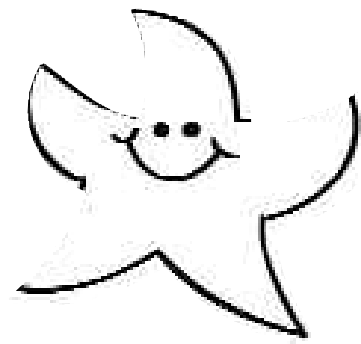

star



teeth



sandwich



run



table

T t



tree



tomato

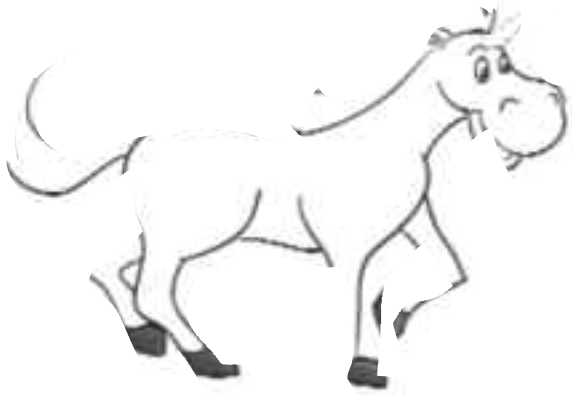

unicorn



umbrella

U

u



uniform



popcorn



**violin**



**swim**

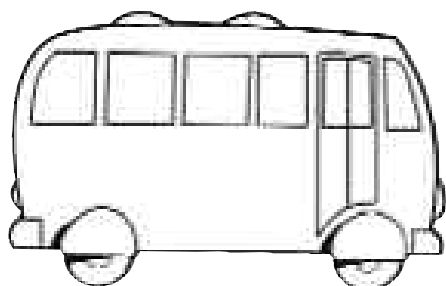

**van**

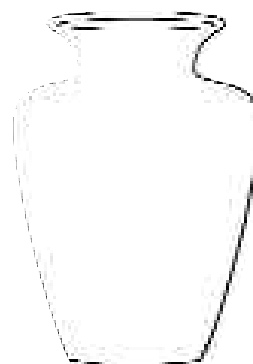

**vase**



window

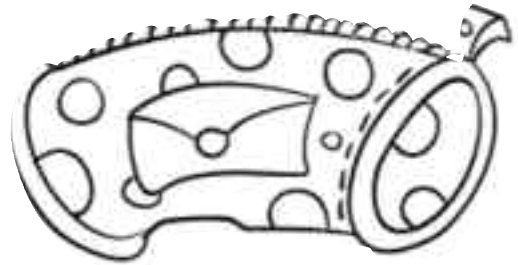

pencil case

W

w



wizard

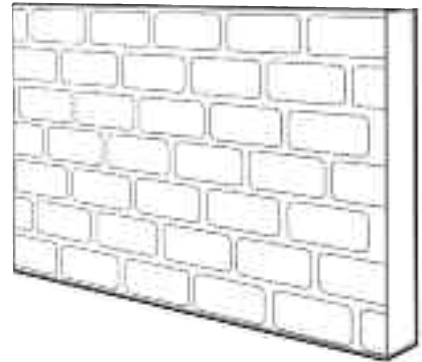

wall



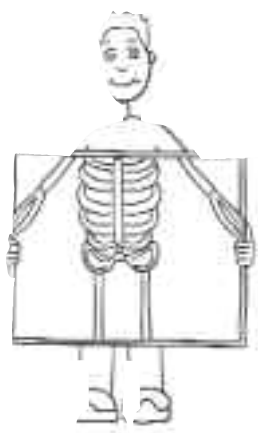

**X**-ray

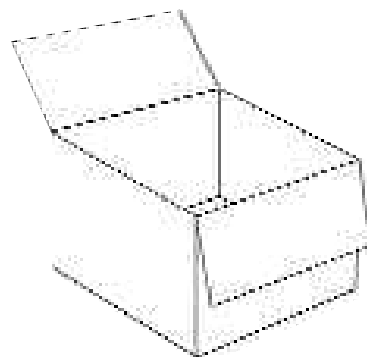

**box**



**fly**



**fox**



yogurt

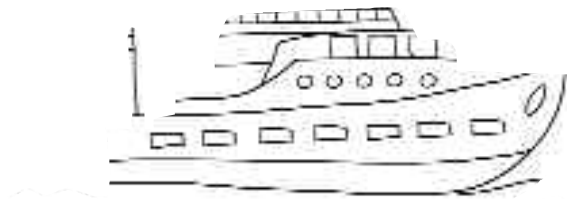

yacht

Y

y



hear



yo-yo



zip



swim

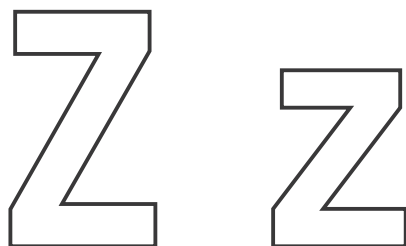

zebra



zero

# Workbook (Key & Instructions)

## MODULE 1 – Hello!

### ★ 1 Complete the picture. Then colour.

Revise the characters' names. Point to each character in turn and elicit the names. Explain the activity and allow the students some time to complete and colour in the picture.

### ★ 2 Join the characters to their hats. Then colour.

Revise the colours. Hold up a green coloured pencil and ask the students to say the correct colour, e.g. *green*. Read the instructions and explain the activity. The students match the characters to their hats and then colour them in. Allow them some time to complete the activity. Check their answers.

Then point to the first hat and ask the students to tell you who it belongs to. Elicit: *Frosty*. Then elicit the colour: *orange*. Repeat for Alvin's hat (*green*) and Woody's hat (*blue*).

### ★ 3 Colour the boxes. Then point and say: (yellow), (blue), ... .

Direct the students' attention to the colour sequence in each row. Explain the activity. Allow the students some time to colour in the boxes. Then point and elicit: *yellow, blue*. Point to the second sequence of colours and elicit: *green, green, red*. Finally, point to the third sequence and elicit the answer: *pink, pink*.

### ★ 4 Colour in and say: My favourite colour is ...

Ask individual students to say what their favourite colour is. Next, direct the students' attention to the circle and tell them to colour it in using their favourite colour. Then they present their colours and say: *My favourite colour is (red)*.

### ★ 5 Look and find the stickers. Then point and say: This is (Erlina).

Read the instructions and explain the task. Ask the students to find the corresponding stickers from the sticker section, and show them to you for verification before sticking them in the appropriate spaces. Check their answers. Then point to the characters, one at a time, and elicit, e.g. *This is Erlina. etc.*

### ★ 6 Find and colour the squares in the picture.

Tell the students to look at the coloured parts of the picture and use them as a colour guide in order to colour the corresponding squares in the big picture. Go around the classroom, asking the students to identify the colours.

## MODULE 2 – My Schoolbag

### ★ 1 Find the school objects and draw lines.

Revise the school objects by pointing to realia in the classroom. Read the instructions and explain the activity. Point to the puzzle pieces of the items around the picture and elicit their names. Point to the example. Allow the students some time to find these items in the picture and draw lines. Check their answers.

### ★ 2 Complete the pictures. The point and say: It's a rubber.

Explain the activity. Allow the students some time to finish drawing the items. Then point to the items, one at a time, and ask individual students to say, 'It's a ...' etc

### ★ 3 Join. Then trace the numbers.

Revise the numbers 1 to 5. Ask the students to look at the numbers Erlina is holding and say them out loud. Then ask them to look at the mushrooms and count the circles on each one. Elicit the answers orally. Point to the example and explain the activity. The students join and trace the numbers. Check their answers.

### ★ 4 Colour the school objects. Then count them and write the correct number.

Point to the book. Ask: *What's this?* Elicit the answer: *It's a book*. Repeat for the rest of the items. Ask the students to colour the school objects. Once they finish, tell the students to count the number of each item in the tree and to write the correct number in the space provided. Check their answers.

books – 2                      pencils – 3                      rubbers – 5  
pens – 4                      pencil case – 1

### ★ 5 Count and find the stickers. Then point and say: one (pencil), two (pencils), ...

Read the instructions and explain the activity. Tell the students to count the items in each box, e.g. *one pencil, three pencils, etc.* Then ask them to find the number of items missing from each sequence. Elicit the answers. Ask the students to find the corresponding stickers from the sticker section, and show them to you for verification before sticking them in the appropriate spaces. Check their answers. Once they finish, students point to the pencils and say: *one pencil, two pencils, three pencils, four pencils, five pencils*. Repeat for the remaining items (*rubbers, books and pens*).

### ★ 6 Use the code and colour in the picture. Then point and say: It's (a red) ... .

Point to number 1 and the colour and ask: *What colour*

*is this?* Elicit: *Red*. Do the same for the remaining numbers and colours. Explain the activity. The students use the code and colour in the picture. Then students point and say: *It's a red book*, etc.

- 1 It's a red book.
- 2 It's a blue pencil.
- 3 It's a green pen.
- 4 It's a yellow pencil case.
- 5 It's an orange rubber.

## MODULE 3 – My Home

- 1** Look. Find the correct part of the house and circle it.

Revise the parts of the house. Point to the pictures of the wall in the first picture and ask: *What's this?* Elicit: *It's a wall*. Repeat for *door*, *window*, *roof*. Explain the activity. Allow the students some time to find the correct part of the house and circle it. Check their answers.

- 2** Follow and colour the items. Then point and say: *This is the (door), It's (blue)*.

Go through the items and elicit their names. Explain the activity. The students follow the paths that lead from the paintbrushes and use the colours to colour in the items. Then point to each item and elicit, e.g. *This is the door. It's blue*, etc.

- 3** Look and draw the correct furniture item. Then point and say: *(bed), (chair), ...*

Direct the students' attention to the pieces of furniture. Go through and elicit their names. Explain the activity. Allow the students some time to look at the order in which the furniture items appear in each row and draw the correct one in the space provided. Then point and elicit their names, e.g. *table*.

table, chair, chair, bed

- 4** Look at the pictures and circle the ones that are the same. Then point and say: *(Alvin)'s in the (house)*.

Read the instructions and explain the activity. Allow the students some time to complete the task. Check their answers. Then point to each picture and elicit: *Alvin's in the house*, etc.

### Pictures to be circled:

Alvin's in the house.  
Woody's in the cupboard.  
Erlina's in the schoolbag.  
Alvin's on the chair.  
Woody's on the table.

Frosty's on the bed.  
Frosty's on the table.  
Erlina's in the pencil case.

- 5** Look at the picture and find the stickers. Then point and say: *It's a (pink chair)*.

Tell the students to look at the half-pictured items inside the tree house and name them. Explain the task. Ask the students to find the corresponding stickers from the sticker section, and show them to you for verification before sticking them in the appropriate spaces. Then point to each item and elicit, e.g. *It's a pink chair*, etc.

- 6** Colour the pictures. Then say: *Frosty's (on) the (chair)*.

Explain the activity. The students colour in the pictures of Frosty. Then point to the picture of Frosty sitting on the chair and elicit: *Frosty's on the chair*. Repeat for the other two pictures.

## MODULE 4 – My Toys

- 1** Colour the pictures. Then point and say: *It's a (plane)*.

Revise the names of the toys. Direct the students' attention to the pictures and tell them to colour them in using the dots as a guide. Allow the students some time to complete the task. Then point to the first picture and ask: *What's this?* Elicit: *It's a plane*. Point to the second picture and elicit: *It's a train*. Repeat the same procedure for *ball* and *teddy*.

- 2** Use the code and colour the pictures. Then point and say: *I've got a (yellow plane)*.

Read the instructions and explain the activity. The students use the key to colour in the toys. Allow them some time to complete the task. Check their answers. Once they finish, they point to each picture and say: *I've got a (yellow plane)*, etc.

- 3** Trace the numbers. Then match them to the pictures. Then point and say: *1 teddy, 2 ...*

Revise the numbers 1 to 10. Read the instructions and explain the activity. The students trace the numbers and match them to the correct picture. Then point to each picture and say: *1 teddy, 2 trains, 3 rubbers, 4 planes, 5 cars, 6 dolls, 7 books, 8 chairs, 9 balls, 10 pencils*.

- 4** Colour the planes. Count and use the key to help you.

Read the instructions and explain the activity. The

# Workbook (Key & Instructions)

students colour in the planes with the help of the key. Allow the students some time to complete the task. Once they finish, the students point to each plane and say: 6 – orange, 7 – green, etc.

## ★ 5 Count the dots and circle the correct number.

Practise addition by writing some simple sums on the board and eliciting the correct answers. Ask the students to count the dots and circle the correct answers. Check their answers.

1	7	3	6
2	10	4	8

## ★ 6 Look at the picture and find the stickers. Then point and say: *I've got a (doll).*

Point to the pictures of the toys and elicit their names. Explain the activity. Ask the students to find the corresponding stickers from the sticker section, and show them to you for verification before sticking them in the appropriate spaces. Then point to the toys, one at a time, and ask the students to say what they have in their boxes, e.g. *I've got a doll.*

## ★ 7 Look at the picture and colour in the cars. Then match the big items to the big car and the small items to the small car.

Revise the meaning of *big/small*. Explain the activity and allow some time for the students to colour in the cars. Then have them match the big items to the big car and the small items to the small car. Check their answers.

ball – big	doll – small
train – small	plane – big
teddy – big	

## MODULE 5 – My Face

### ★ 1 Look and find the stickers. Then point and say: *(Frosty)'s got a (mouth).*

Revise the parts of the face. Ask the students to find the corresponding stickers from the sticker section, and show them to you for verification before sticking them in the appropriate spaces. Then point to each character and elicit, e.g. *(Frosty)'s got a (mouth).* etc.

### ★ 2 Draw the part of the face that is missing in each picture.

Read the instructions and explain the activity. Point to each picture and ask the students to say what part of the face is missing, e.g. *a nose, etc.* Ask the students to

draw what's missing in each picture. Have students show their drawings to the class once they finish.

### ★ 3 Draw lines to match. Then point and say: *(Wash) your (hands).*

Explain the activity. The students draw lines to match the pictures to their silhouettes. Check their answers. Then point to each picture and say the actions (*wash your hands, wash your face, brush your teeth, brush your hair*).

### ★ 4 Look and colour the picture. Then say: *He's got (blue hair).*

Read the instructions and explain the activity. Allow the students some time to use the code and colour in the picture. Then students point to and say, e.g. *He's got (blue hair).* etc.

### ★ 5 Look at the pictures and say: *You've got big (eyes).*

Read the instructions and explain the activity. Point to each picture and elicit what the character is saying, e.g. *You've got big eyes.* etc.

### ★ 6 Look at the pictures. Circle the differences. Then point and say: *He's got (blue hair). He's got (green hair).*

Ask the students to look at the two pictures and elicit the differences. Allow the students some time to circle the differences. Then individual students point to each of the differences and say, e.g. *He's got blue hair. He's got green hair.* etc.

<b>A</b>	<b>B</b>
He's got a big nose.	He's got a small nose.
He's got big ears.	He's got small ears.
He's got blue hair.	He's got green hair.
She's got a small nose.	She's got a big nose.
She's got a big mouth.	She's got a small mouth.
She's got blue eyes.	She's got pink eyes.

## MODULE 6 – My Food

### ★ 1 Draw lines to match the food items to the silhouettes.

Revise the names of the food items. Explain the activity. Allow the students some time to match the food items to their silhouettes by drawing lines. Check their answers.

- 2** Look at the shopping list. Draw the food items. Then, say: *Give me some (cheese), please.*

Read the instructions and explain the activity. Point to the shopping list and elicit the names of the items. Tell the students to draw the food items on their list in the basket. Allow them some time to finish their drawings. Then they say: *Give me some (cheese), please.* etc.

- 3** Match the children to the food items.

Direct the students' attention to the pictures of the children. Then point to each food item and elicit the correct name. Tell the students to match the children to their food items.

- |          |           |             |
|----------|-----------|-------------|
| 1 cola   | 3 popcorn | 5 ice cream |
| 2 banana | 4 egg     |             |

- 4** Use the key and draw. Then say: *I like/don't like (pizza).*

Point to each face and say: *I like ... I don't like ...* Go through the pictures and elicit the names of the food items. Explain the activity. The students draw a smiley face or a frown face depending on whether they like the food items or not. Once they finish, they say which food items they like and which ones they don't.

- 5** Look at the picture and find the stickers. Then point and say: *I like/don't like apples.*

Tell the students to look at the picture of the characters having tea and name the half-pictured items. Ask the students to find the corresponding stickers from the sticker section, and show them to you for verification before sticking them in the appropriate spaces. Then point to each item and elicit, e.g. *I like/don't like (apples).* etc.

- 6** Draw what you like/don't like. Then say: *I like ... Yummy!/I don't like ... Yuk!*

Go through the food items and elicit their names. Explain the activity. Tell the students to draw the food items they like/don't like on the trays. Then the students present their drawings to the class and say: *I like (ice cream). Yummy! I don't like (eggs). Yuk!*

## MODULE 7 – My Animals

- 1** Colour the animals. Then point and say: *It's a yellow horse.*

Revise the names of the animals. Explain the activity. The students colour in the pictures using a colour of their choice. Allow them some time to complete the

task. Then point to the horse and elicit: *It's a (yellow) horse.* etc.

- 2** Count the animals and write the numbers.

Read the instructions and explain the activity. Ask the students to count the animals and write the numbers in the spaces provided. Check their answers.

- |          |           |
|----------|-----------|
| cats – 4 | cows – 3  |
| hens – 5 | sheep – 1 |
| dogs – 2 | horse – 1 |

- 3** Complete the pictures. Then colour.

Revise the verb *can*. Read the instructions and explain the activity. The students trace the items and colour them in. Then point to each picture and ask the students to say what each child can do. Elicit their answers.

- |              |             |
|--------------|-------------|
| I can jump.  | I can run.  |
| I can fly.   | I can swim. |
| I can climb. |             |

- 4** Look at the picture and say: *I can (fly).*

Point to the pictures of the animals, one at a time, and elicit the actions. Then ask the students to point to each animal and say, e.g. *I can fly.* etc. As an extension, you can ask the students to colour in the picture.

- 5** Look at the pictures and find the stickers. Then play with your friend. Name the animals.

Tell the students to look at the pictures of the animals and elicit their names. Ask the students to find the corresponding stickers from the sticker section, and show them to you for verification before sticking them in the appropriate spaces.

Explain the game. The students play the game in pairs. Ask the students to use a coin, a sharpener, etc as a marker and place it on the *Start* sign. The pairs take it in turns to select a number by throwing a dice and then move along the board according to the number. The students must name the item in the square they land on. A correct answer allows the students to stay where they are, whereas an incorrect one means that they must go back to the *Start* sign. If they land on a *Oh, no!* square, they must go back to the start, if they land on a *Great!* square they play again.

- 6** Draw lines to show what you can do and what you can't do. Then talk with your friend: *I can (jump). Can you (jump)?*

Point to the picture of the two children talking and the speech bubble of the horse. Say: *I can jump. Can you*



# Workbook (Key & Instructions)

*jump?* The students repeat after you. Explain the activity. In pairs, the students draw lines to the smiley face or the frown face, depending on what they can do and what they can't do. Then they ask and answer, e.g. *I can climb. Can you climb? etc.*

## MODULE 8 – My Senses

**1** **Circle the odd one out. Then point and say: (smell), (touch), ... .**

Revise the senses. Read the instructions and explain the activity. The students circle the odd one out. Ask them to justify their answers.

picture of look                      picture of hear  
picture of touch                    picture of touch  
picture of smell

**2** **Look at the pictures, point and say: I can (see a mouse).**

Read the instructions and explain the activity. Point to the pictures, one at a time, and ask the students to say what they can see, e.g. *I can see a mouse. etc.*

**3** **Count and write the correct number.**

Ask the students to look at the picture of Frosty. Explain the activity. Tell them to count the items and write the correct number in the spaces provided. Check their completed work.

sun – 7                      moon – 9                      star – 10

**4** **Complete the pictures for day and night. Then colour and say: It's (day).**

Point to the incomplete pictures. Ask the students to complete the pictures for day and night by drawing things that apply to each picture. Then have them colour in their drawings. Once they finish, the students present their drawings to the class and say: *It's day! Look at the sun! Look at the flowers! etc.*

**5** **Look and find the stickers.**

Direct the students' attention to the picture. Explain the activity. Ask the students to find the corresponding stickers from the sticker section, and show them to you for verification before sticking them in the appropriate spaces.

**6** **Follow the path and draw. Then say: (Willow) can (see) a (star).**

Explain the activity. The students follow the lines, look at the pictures and say what things they can see, hear,

smell, touch and taste, e.g. *Willow can see the stars. etc.*

Alvin can hear a cat.  
Erlina can smell popcorn.  
Woody can touch a ball.  
Frosty can taste an ice cream.

## MY ALPHABET

### A-B

**1** **Trace the letters. Then write the letters.**

Read the instructions and explain the task. The students trace and write the letters.

**2** **Circle the *apples* and the *beds*.**

Read the instructions and explain the task. Students look at the words and circle the words *apple* and *bed*.

### C-D

**1** **Trace the letters. Then write the letters.**

Read the instructions and explain the task. The students trace and write the letters.

**2** **Match the upper case to the lower case letters. Then, colour in the pictures.**

Read the instructions and explain the task. The students draw lines and match the letters. Then they colour in the pictures accordingly. Allow students some time to complete the task. Go around the classroom, giving help where necessary.

### E-F

**1** **Trace the letters. Then write the letters.**

Read the instructions and explain the task. The students trace and write the letters.

**2** **Draw lines to match the pictures to the letters. Then point and say: (a) is for (apple).**

Read the instructions and explain the task. Students draw lines to match the letters to the pictures. Then, they point and say the letters and the words.

a - apple: A is for apple  
b - bed: B for bed  
c - cat: C if for cat  
d - dog: D is for dog  
e - egg: E is for egg  
f - fish: F is for fish

# Workbook (Key & Instructions)

## G-H

### 1 Trace the letters. Then write the letters.

Read the instructions and explain the task. The students trace and write the letters.

### 2 Match the upper case to the lower case letters.

Read the instructions and explain the task. Students match the upper case with the lower case letters. Allow students some time to complete the task. Go around the classroom providing help where necessary.

## I-J

### 1 Trace the letters. Then write the letters.

Read the instructions and explain the task. The students trace and write the letters.

### 2 Trace the words. Then circle the right pictures.

Read the instructions and explain the task. Students look at the pictures and the upper case letters and circle the corresponding lower case letter.

- 1 students circle the iguana
- 2 students circle the jug
- 3 students circle the fish
- 4 students circle the bed

## K-L

### 1 Trace the letters. Then write the letters.

Read the instructions and explain the task. The students trace and write the letters.

### 2 Circle the right lower case letter.

Read the instructions and explain the task. Students look at the pictures and the upper case letters and circle the corresponding lower case letter.

A - a   D - d   F - f   G - g   K - k   L - l

## M-N

### 1 Trace the letters. Then write the letters.

Read the instructions and explain the task. The students trace and write the letters.

### 2 Find the words then match them to the pictures.

Read the instructions and explain the task. Students

match the words to the pictures. Allow students some time to complete the task. Go around the classroom giving help where necessary.



## O-P

### 1 Trace the letters. Then write the letters.

Read the instructions and explain the task. The students trace and write the letters.

### 2 Trace the words. Then circle the right pictures.

Read the instructions and explain the task. The students trace the words and circle the corresponding pictures.

- 1 students circle the orange
- 2 students circle the pen
- 3 students circle the cat
- 4 students circle the glass

## Q-R

### 1 Trace the letters. Then write the letters.

Read the instructions and explain the task. The students trace and write the letters.

### 2 Write the letters.

Read the instructions and explain the task. Students write the letters in upper or small case accordingly. Allow students some time to complete the task. Go around the classroom, giving help where necessary.

## S-T

### 1 Trace the letters. Then write the letters.

Read the instructions and explain the task. The students trace and write the letters.

# Workbook (Key & Instructions)

## ★ 2 Look at the pictures and trace the right words.

Read the instructions and explain the task. Students look at the pictures and trace the correct word.

1 snake    2 tree    3 queen    4 rabbit

## U-V

### ★ 1 Trace the letters. Then write the letters.

Read the instructions and explain the task. The students trace and write the letters.

### ★ 2 Write the missing letters.

1 umbrella    3 iguana    5 lion  
2 car    4 glass    6 kitten

## W-X

### ★ 1 Trace the letters. Then write the letters.

Read the instructions and explain the task. The students trace and write the letters.

### ★ 2 Unscramble the letters and write the words.

Read the instructions and explain the task. Students unscramble the letters and write the letters. Allow students some time to complete the task. Go around the classroom, giving help where necessary.

1 dog    3 hen    5 fish  
2 cat    4 fox    6 rabbit

## Y-Z

### ★ 1 Trace the letters. Then write the letters.

Read the instructions and explain the task. The students trace and write the letters.

### ★ 2 Write the missing letters.

Read the instructions and explain the task. Students write the missing letters.

**b, c, d, e, h, l, j, l, n, o, p, q, t, w, v, z**

## A-Z

### ★ 1 Follow the alphabet.

Read the instructions and explain the task. Student draw lines to follow the alphabet.

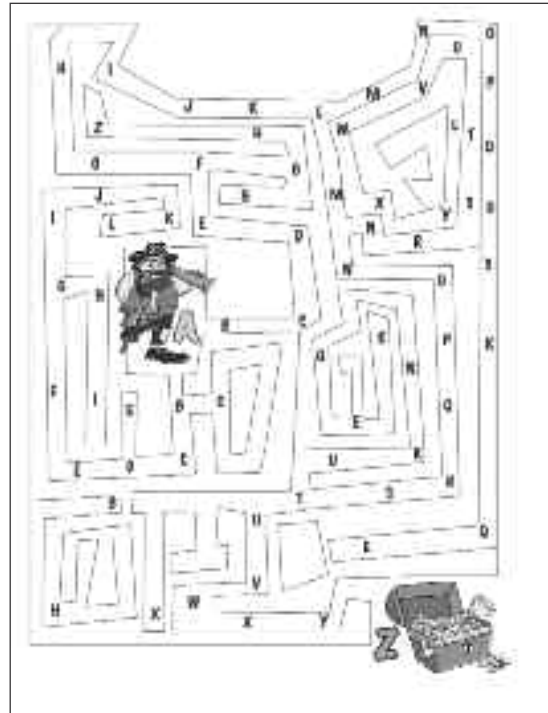

## BOARD GAMES (1-4)

For rules on how to play the board games, see the Introduction, p. VI.

# Notes

# Notes